

Sisällysluettelo \ Innehållsförteckning \ Contents \ Inhaltsverzeichnis

<i>Pääkokoonpano \ Sammansättning \ Final assembly \ Zusammensetzung</i>	<i>1</i>
<i>Kääntölaite \ Vridanordning \ Slew mechanism \ Schwenkwerk.....</i>	<i>3</i>
<i>Tukijalkavarustus \ Stödbensutrustning \ Stabilizers \ Stützfußausrüstung.....</i>	<i>5</i>
<i>Nostopuomi \ Lyftbom \ Main lifting boom \ Hubarm</i>	<i>7</i>
<i>Siirtopuomisto \ Vipparm \ Outer boom \ Knickarm</i>	<i>17</i>
<i>Vetotangon varustelu \ Dragstång \ Inner link assy \ Mittleres Gelenk.....</i>	<i>24</i>
<i>Nostosylinteri \ Lyftcylinder \ Main lifting cylinder \ Hubzylinder</i>	<i>25</i>
<i>Siirtosylinteri \ Vippcylinder \ Outer boom cylinder \ Knickarmzylinder.....</i>	<i>27</i>
<i>Jatkeen sylinteri \ Utskjutscylinder \ Extension cylinder \ Ausschubzylinder \</i>	<i>29</i>
<i>Tukijalkojen levityssylinteri \ Spridningscylinder \ Spreading cylinder \ Ausshubzylinder für Stützfüsse</i>	<i>31</i>
<i>Tukijalan sylinteri \ Stödbenscylinder \ Stabilizer cylinder \ Stützfußcylinder</i>	<i>33</i>
<i>Painesuodatin \ Tryckfilter \ Pressure filter \ Druckfilter</i>	<i>35</i>
<i>Nosturin asennus \ montering \ mounting \ Aufstellung.....</i>	<i>37</i>
<i>Painesuodatin asennusteline \ Tryckfilter montering \ Pressure filter mounting \ Druckfilter Aufstellung</i>	<i>39</i>
<i>Hallintalaitteet \ Styrningsanordning \ Control unit \ Bedienungsanordnung \</i>	

90000293

NOSTURI

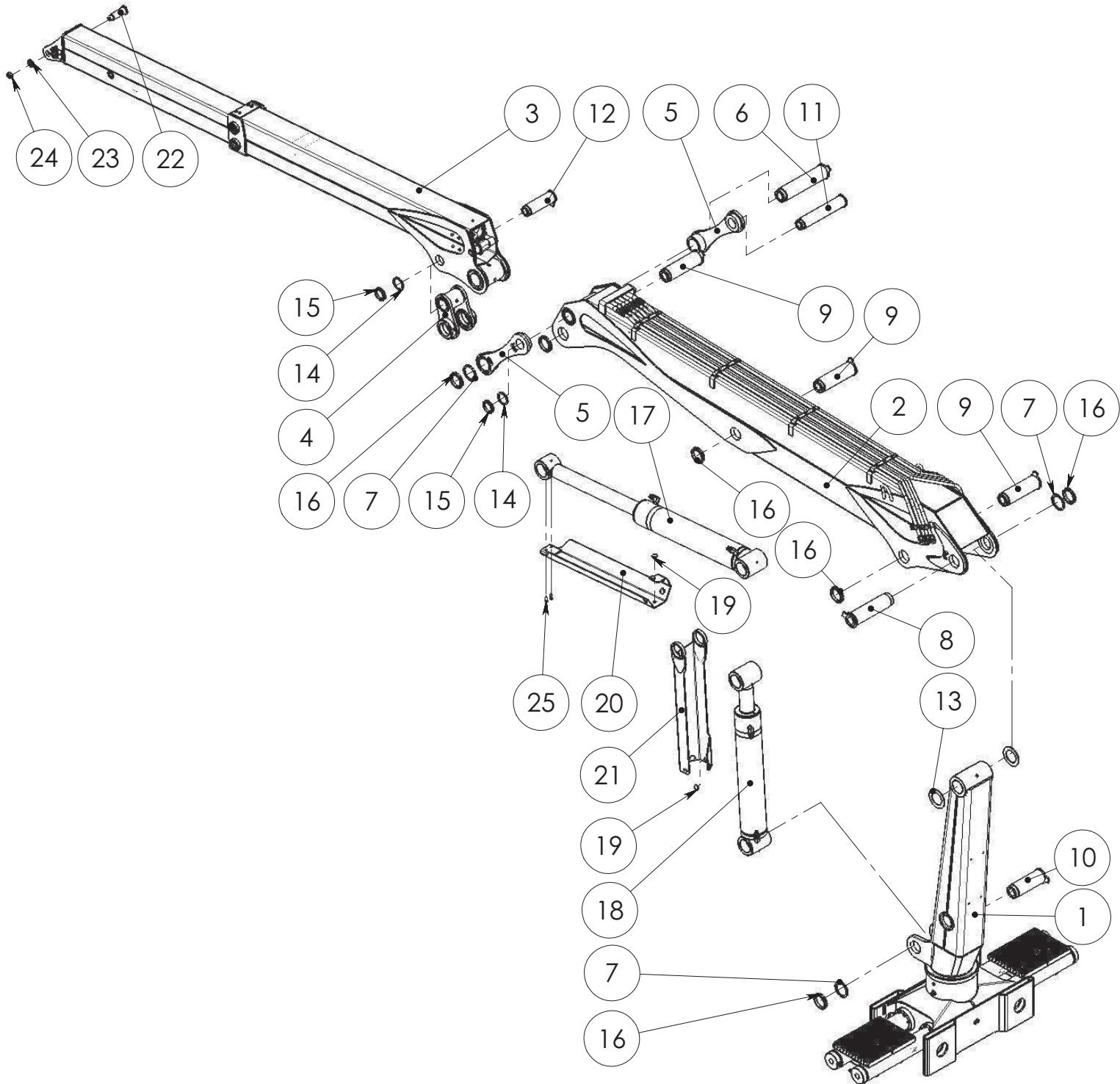



SPARE PART LIST

Item code	9000293	Revision	-
Title	NOSTURI	Date	16.01.2006
Specification	FORESTERI 2024		

Pos	Item code	Title	Specification	Dimensions	Pc	Amount	Unit	Nto Weight
1	90020496	KÄÄNTÖLAITE SVÄNGVERK SLEW MECHANISM SCHWENKWERK			1			1039.44
2	90020597	NOSTOJUOMI LYFTBOM LIFT BOOM HUBARM	VAR		1			564.18
3	90020589	PUOMI BOM BOOM ARM	1-JATK. VAR		1			428.85
4	90020495	TANKO LÄNK LINK GELENK	VAR		1			21.96
5	90020446	TANKO LÄNK LINK GELENK	KONEISTUS		2			14.28
6	90020454	AKSELI AXEL AXLE ACHSE	100-457		1			19.33
7	90015230	ALUSLEVY BRICKA WASHER UNTERLEGSCHEIBE	125/101-6	65x65	3			0.2
8	90020453	AKSELI AXEL AXLE ACHSE	100-397		1			16.79
9	90020452	AKSELI AXEL AXLE ACHSE	100-348		3			14.75
10	90020451	AKSELI AXEL AXLE ACHSE	100-307		1			12.98
11	90020470	AKSELI AXEL AXLE ACHSE	80-450		1			12.12
12	90020469	AKSELI AXEL AXLE ACHSE	80-280		1			7.53
13	90010010	LAAKERI LAGER BEARING LAGER	152/100.5-5	142x142	2			0.06
14	90013697	ALUSLEVY BRICKA WASHER UNTERLEGSCHEIBE	100/81-6	65x65	2			0.13
15	3020158	MUTTERI MUTTER NUT MUTTER	KM 15 NYLOC M75X2		2			0.35
16	3020166	MUTTERI MUTTER NUT MUTTER	KM 19 NYLOC M95X2		6			0.54
17	28763001	SYLINTERI CYLINDER ZYLINDER ZYLINDER	160/100 X 855 (SIIRTO)		1			164.24
18	28762001	SYLINTERI CYLINDER ZYLINDER ZYLINDER	160/100 X 855 (NOSTO)		1			168.99
19	90013832	LIUKUPALA GLIDKLACK GUIDE PAD GLEITLAGER	40-14	L=16	10			0.01
20	90020579	SUOJA SKYDD COVER SCHUTZ	SIIRTOSYL.		1			15.95
21	90020586	SUOJA SKYDD COVER SCHUTZ	NOSTOSYL.		1			20.16
22	90013105	AKSELI AXEL AXLE ACHSE	45-164	L=207	1			1.94
23	90013106	ALUSLEVY BRICKA WASHER UNTERLEGSCHEIBE	56/31-8	65x65	1			0.09
24	3020144	MUTTERI MUTTER NUT MUTTER	KM6 M30X1.5 ZN NYLOC		1			0.1
25	3010246	RUUVI SKRUV SCREW SCHRAUBE	KKR M12 X 30.8.8.ZN DIN 912		2			0

90020496

KÄÄNTÖLAITE

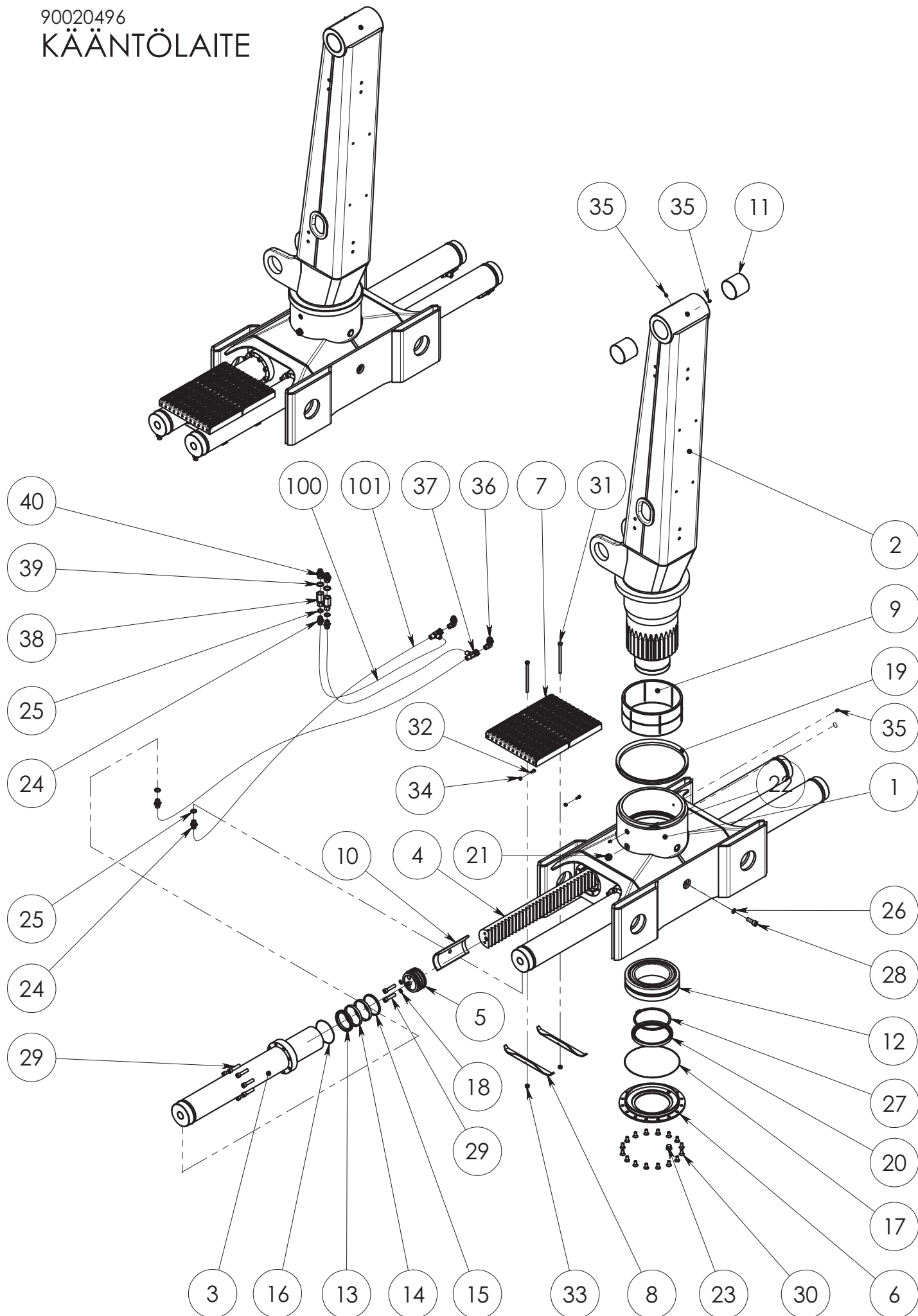



SPARE PART LIST

Item code	90020496	Revision	A
Title	KÄÄNTÖLAITE	Date	30.03.2005
Specification	42 kNm		

Pos	Item code	Title	Specification	Dimensions	Pc	Amount	Unit	Nto Weight
1	90020672	KÄÄNTÖLAITE VRIDANORDNING SLEW MECHANISM SCHWENKWERK	RUNKO, VAIHE 2 HITS		1			329.36
2	90020412	PYLVÄS PELARE PILLAR SÄULE	KONEISTUS		1			450.59
3	90020400	SYLINTERI CYLINDER CYLINDER ZYLINDER	115-973		4			27.6
4	90020396	HAMMASTANKO KUGGSTÅNG RACK BAR ZAHNSTANGE	100-1105	L=1107	2			44.59
5	90019738	MÄNITÄ KOLV PISTON KOLBEN	D=115	L=92	4			4.07
6	90020387	LAIPPA FLÄNS FLANGE FLANSCH		346x346	1			5.26
7	90013146	PORRAS TRAPPSTEG STEP STEG			2			2.25
8	90010239	LATTI PLATTI FLAT BAR FLACH		360x55	2			0.58
9	90020401	LAAKERI LAGER BEARING LAGER	310/290-140	L=102	1			1.48
10	90020397	LAAKERI LAGER BEARING LAGER	105/127 6-227	L=229	2			0.34
11	3100176	LAAKERI LAGER BEARING LAGER	WB 802 10095		2			0.6
12	3100345	LAAKERI LAGER BEARING LAGER	23036 CC/W33		1			13
13	3110768	MÄNNÄNTIVISTE KOLV TÄTNING PISTON SEAL KOLBENDICHTUNG	T18 115/95X13		4			0.28
14	3110769	OHJAIN STYRNING GUIDANCE STEUERUNG	E/PWR 115/109X13		8			0.1
15	3110770	TIIVISTE TÄTNING SEAL DICHTUNG	PPW 1115/106.4X5.3		4			0.07
16	3110461	TIIVISTE TÄTNING SEAL DICHTUNG	124.5X3.0 70 SHORE		4			0.02
17	3110785	TIIVISTE TÄTNING SEAL DICHTUNG	280X3.0 70 SHORE		1			0.05
18	3110652	TIIVISTE TÄTNING SEAL DICHTUNG	M14 14.7X21.0X1.5		8			0
19	3110869	TIIVISTE TÄTNING SEAL DICHTUNG	VA-350		1			1.93
20	3110870	TIIVISTE TÄTNING SEAL DICHTUNG	180/210 X 15 DIN 3760 AS		1			0.59
21	3091042	HUOHOTIN FLÄMMENTIL BREATHER ENTLÜFTER			1			0.11
22	3090294	OSOITIN INDIKATOR INDICATOR ANZEIGER			1			0.01
23	3090212	TULPPA PLUGG PLUG DECKEL			1			0.05
24	3090019	LIITIN KOPPLINGSSTYCKE CONNECTOR KONNEKTOR	04000-08 R 1/2"		4			0.1
25	3110042	TIIVISTE TÄTNING SEAL DICHTUNG	R-08 R 1/2"		4			0.01
26	3110040	TIIVISTE TÄTNING SEAL DICHTUNG	R-06 R 3/8"		2			0
27	3060097	PIDÄTINRENGAS LÄSRING SNAP RING SPRENGRING	180X4 DIN 471		1			0
28	3010273	RUUVI SKRUV SCREW SCHRAUBE	M16X45 8.8 DIN 912		2			0
29	3010601	RUUVI SKRUV SCREW SCHRAUBE	M14X60 12.9 DIN 912		40			0
30	3010315	RUUVI SKRUV SCREW SCHRAUBE	M12X25 10.9 ZN DIN 7991		16			0
31	3010670	RUUVI SKRUV SCREW SCHRAUBE	M10X180 8.8 ZN DIN 931		2			0
32	3010292	RUUVI SKRUV SCREW SCHRAUBE	M8X16 8.8 ZN DIN 912		2			0
33	3020004	MUTTERI MUTTER NUT MUTTER	M10 ZN DIN 985		2			0.01
34	3020001	MUTTERI MUTTER NUT MUTTER	M8 ZN DIN 985		2			0.01
35	3050020	RASVANIPPA SMÖRJNIPPEL GREASE NIPPLE SCHMIERNIPPEL	R 1/8" ZN		4			0.01
36	3090428	LIITIN KOPPLINGSSTYCKE CONNECTOR KONNEKTOR	26-04500-08		2			0.17



SPARE PART LIST

Item code	90020496	Revision	A
Title	KÄÄNTÖLAITE	Date	30.03.2005
Specification	42 kNm		

Pos	Item code	Title	Specification	Dimensions	Pc	Amount	Unit	Ntto Weight
37	3091107	LIITIN (T) KOPPLINGSSTYCKE (T) CONNECTOR (T) T-KUPPLUNG	04880-08		2			0.24
38	3090368	LIITIN KOPPLINGSSTYCKE CONNECTOR KONNEKTOR	TEMA 500		2			0.32
39	3110130	TIIIVISTE TÄTINING SEAL DICHTUNG	R-12 R 3/4"		2			0.01
40	3090053	LIITIN KOPPLINGSSTYCKE CONNECTOR KONNEKTOR	04000-08-12		2			0.14
100	3130994S	LETKU SLANG HOSE SCHLAUCH	5201-08/HI-98C-08/5251-08/L=2000		2			
101	3130489S	HYDRAULILETKU HYDRAULIKSLANG HYDRAULIC HOSE HYDRAULIKSCHLAUCH	5251-08/HI-98C-08/5201-08/L=2200 TEX		2			



SPARE PART LIST

Item code	90020806	Revision	-
Title	TUKI	Date	09.02.2006
Specification	JALKAVAR		

Pos	Item code	Title	Specification	Dimensions	Pc	Amount	Unit	Nto Weight
1	90020785	PALKKI BALK BEAM BALKEN	HITS		1			126.28
2	90020793	VARSII SPAKSTÄNG STEERINGARM GRIFF	HITS		2			52.23
3	90011249	AKSELI AXEL AXLE AXHSE	HITS		2			1.43
4	90012844	VIPU SPAK LEVER HEBEL	HITS		2			0.16
5	28773001	SYLINTERI CYLINDER CYLINDER ZYLINDER	110/90 X 600		2			30.54
6	28812001	SYLINTERI CYLINDER CYLINDER ZYLINDER	50/30 X 2 X 600		1			8.11
7	90011250	LAIPPA FLÄNS FLANGE FLANSCH	145X145		2			0.73
8	90012843	KARA SPINDEL SPINDLE SPINDEL	28/18-76	L=78	2			0.2
9	90020802	AKSELI AXEL AXLE AXHSE	30-122	L=104	2			0.68
10	90020807	LIUKUPALA GLIDKLACK GLIDE PAD GLEITLAGER		L=8	4			0.01
11	90016090	KIINNIKE FÄSTE FASTENER BEFESTIGUNG		L=37	2			0.35
12	3120453	NUPPI KNAPP KNOB KNOPF	52401HI-FLEX		2			
13	3300533	JOUSI FJÄDER SPRING FEDER	SF-TF3/18/45/7.6/6.88		2			
14	90011001	LIUKUPALA GLIDKLACK GLIDE PAD GLEITLAGER	D=55-19/7	L=20	2			0.03
15	3060019	PIDÄTINRENGAS LÄSRING SNAPRING SPRENGRING			4			0
16	3010672	RUUVI SKRUV SCREW SCHRAUBE	30 DIN 472		1			0
17	3010312	RUUVI SKRUV SCREW SCHRAUBE	KR M20X200 ZN 8.8 DIN 931		4			0
18	3010048	RUUVI SKRUV SCREW SCHRAUBE	KKR M20X30 10.9 ZN DIN 913		4			0
19	3010447	RUUVI SKRUV SCREW SCHRAUBE	KR M12 X 30 8.8 ZN DIN 933		8			0
20	3010441	RUUVI SKRUV SCREW SCHRAUBE	KR M8 X 100 8.8 ZN DIN 931		2			0
21	3020009	MUTTERI MUTTER NUT MUTTER	KR M8 X 40 8.8 ZN DIN 931		2			0
22	3020014	MUTTERI MUTTER NUT MUTTER	KM M20 ZN DIN 985		1			0
23	3020001	MUTTERI MUTTER NUT MUTTER	KM M20 ZN DIN 936		4			0
24	3030096	ALUSLEVY BRICKA WASHER UNTERLEGSCHIBE	KM M8 ZN DIN 985		4			0
25	3110071	TIIVISTE TÄTNING SEAL DICHTUNG	M12 DIN 125 ZN		8			0.01
			O 94.5 X 3 90 SH		4			0.02

90020597

NOSTOPUOMI 4.0m

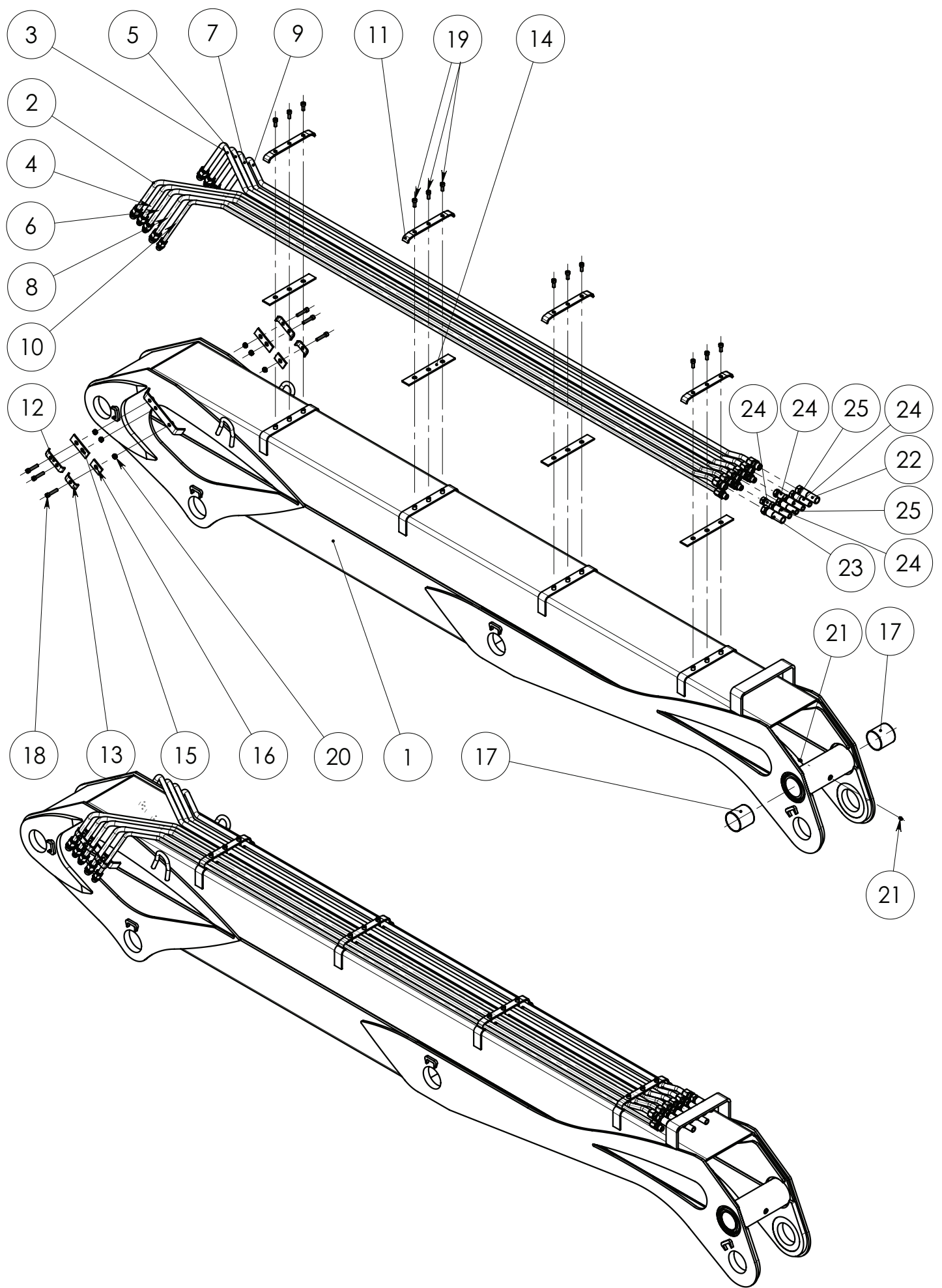



SPARE PART LIST

Item code	90020597	Revision	-
Title	NOSTOPUOMI	Date	23.05.2005
Specification	VAR 4.0		

Pos	Item code	Title	Specification	Dimensions	Pc	Amount	Unit	Nto Weight
1	90020430	NOSTOPUOMI LYFTBOM LIFT BOOM HUBARM	KONESTUS (4.0)		1			523.44
2	90020599	PUTKI RÖR PIPE ROHR	1 OIKEA KOK		1			4.14
3	90020600	PUTKI RÖR PIPE ROHR	1 VASEN KOK		1			4.54
4	90020603	PUTKI RÖR PIPE ROHR	2 OIKEA KOK		1			4.51
5	90020605	PUTKI RÖR PIPE ROHR	2 VASEN KOK		1			4.51
6	90020609	PUTKI RÖR PIPE ROHR	3 OIKEA KOK		1			4.04
7	90020611	PUTKI RÖR PIPE ROHR	3 VASEN KOK		1			4.45
8	90020613	PUTKI RÖR PIPE ROHR	4 OIKEA KOK		1			4.07
9	90020615	PUTKI RÖR PIPE ROHR	4 VASEN KOK		1			4.46
10	90020618	PUTKI RÖR PIPE ROHR	5 OIKEA KOK		1			2.94
11	90020625	KIINNIKE FÄSTE FASTENER BEFESTIGUNG	6X30-284	L=284	4			0.38
12	90013168	KIINNIKE FÄSTE FASTENER BEFESTIGUNG	4X30-112	L=112	2			0.1
13	90010442	KIINNIKE FÄSTE FASTENER BEFESTIGUNG	LT4X30-72	L=72	2			0.07
14	90020626	KUMI GUMMI RUBBER GUMMI	5X40-265	L=265	4			0.07
15	90013174	KUMI GUMMI RUBBER GUMMI			2			0.02
16	90010443	KUMI GUMMI RUBBER GUMMI		L=55	2			0.01
17	3100187	LAAKERI LAGER BEARING LAGER	WB 802 8080		2			0.41
18	3010137	RUIUVI SKRUV SCREW SCHRAUBE	KKR M10X50 8.8 ZN DIN 912		6			0
19	3010685	RUIUVI SKRUV SCREW SCHRAUBE	KKR M10X25 8.8 DIN 912 ZN		12			0
20	3020004	MUTTERI MUTTER NUT MUTTER	KM M10 ZN DIN 985		6			0
21	3050003	RASVANIPPA SMÖRJNIPPEL GREASE NIPPLE SCHMIERNIPPEL	M8X1,25 DIN 71412		2			0
22	3131720	LETKU SLANG HOSE SCHLAUCH	5601-12/ HI-33-12/5660-12/L=1250		1			0.98
23	3132308	LETKU SLANG HOSE SCHLAUCH	5601-12/HI33-12/5601-12.L=2050		1			0.77
24	3130357	LETKU SLANG HOSE SCHLAUCH	5201-08/HI-98C-08/5201-08/L=1300		4			0.56
25	3130846	LETKU SLANG HOSE SCHLAUCH	5751-08/HI98C-08/5701-08/L=1250		2			0.67

90020854

NOSTOPUOMI

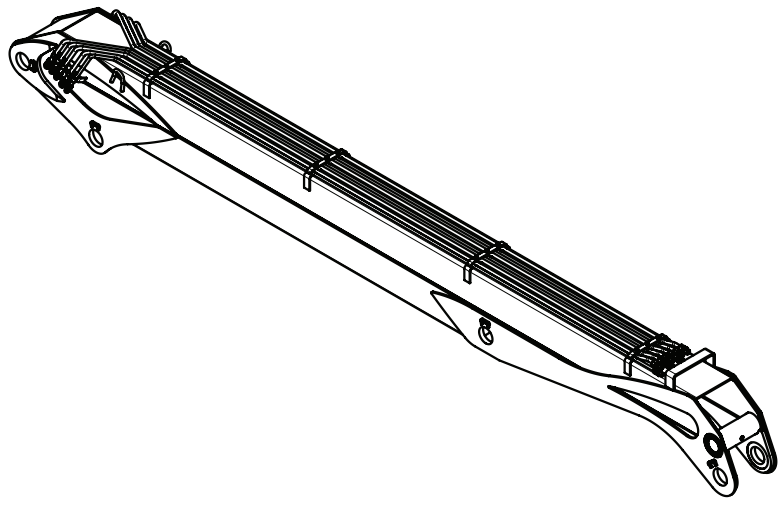
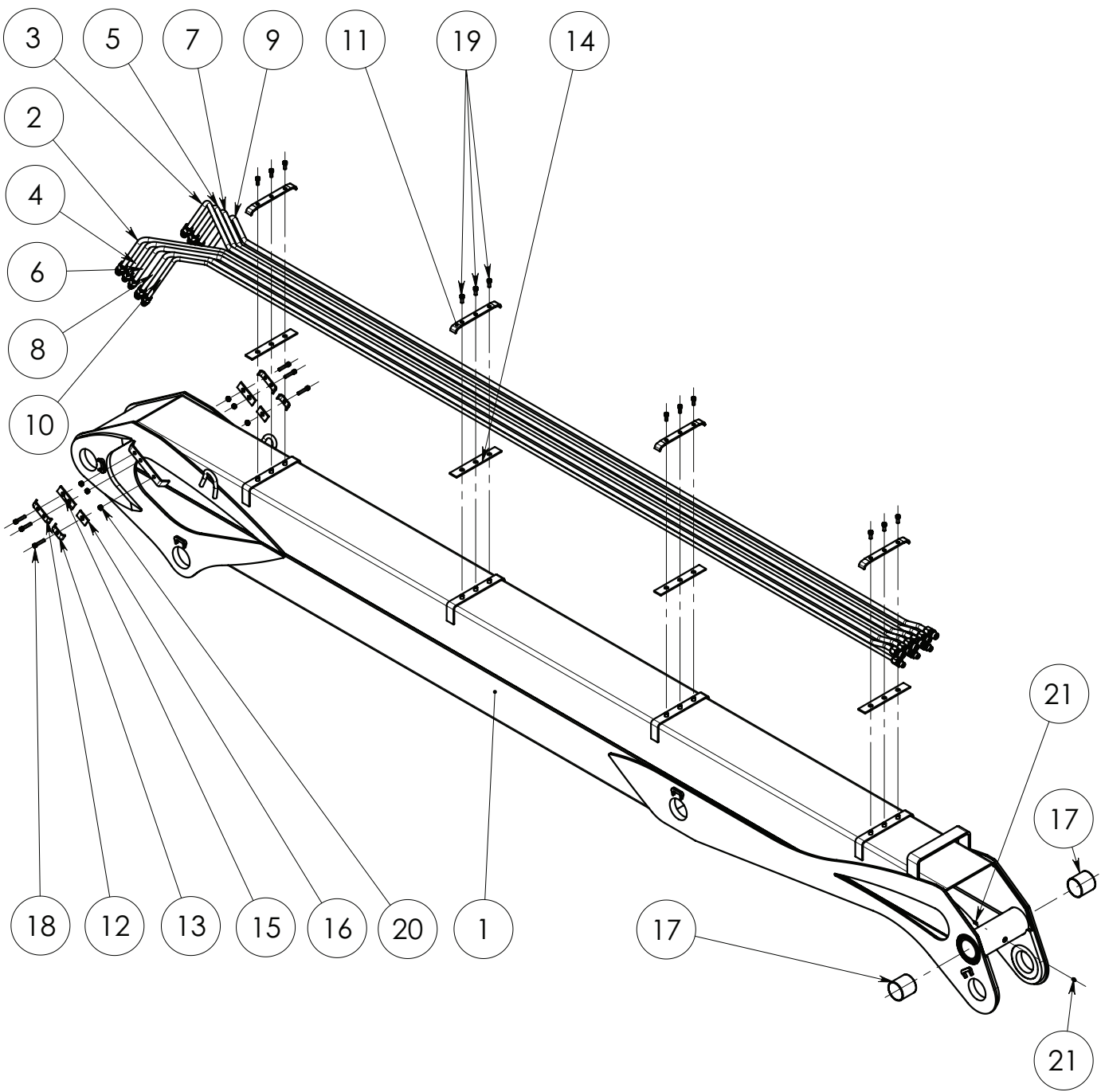



SPARE PART LIST

Item code	90020854	Revision	-
Title	NOSTOPUOMI	Date	21.09.2005
Specification	(5.2) VAR		

Pos	Item code	Title	Specification	Dimensions	Pc	Amount	Unit	Nto Weight
1	90020832	NOSTOPUOMI LYFTBOM LIFT BOOM HUBARM	KONESTUS (5.2)		1			631.84
2	90020834	PUTKI RÖR PIPE ROHR	1 OIKEA KOK		1			5.47
3	90020836	PUTKI RÖR PIPE ROHR	1 VASEN KOK		1			5.86
4	90020838	PUTKI RÖR PIPE ROHR	2 OIKEA KOK		1			5.8
5	90020840	PUTKI RÖR PIPE ROHR	2 VASEN KOK		1			5.8
6	90020842	PUTKI RÖR PIPE ROHR	3 OIKEA KOK		1			5.34
7	90020844	PUTKI RÖR PIPE ROHR	3 VASEN KOK		1			5.74
8	90020848	PUTKI RÖR PIPE ROHR	4 OIKEA KOK		1			5.36
9	90020850	PUTKI RÖR PIPE ROHR	4 VASEN KOK		1			5.76
10	90020852	PUTKI RÖR PIPE ROHR	5 OIKEA KOK		1			3.77
11	90020625	KIINNIKE FÄSTE FASTENER BEFESTIGUNG	6X30-284	L=284	4			0.38
12	90013168	KIINNIKE FÄSTE FASTENER BEFESTIGUNG	4X30-112	L=112	2			0.1
13	90010442	KIINNIKE FÄSTE FASTENER BEFESTIGUNG	LT4X30-72	L=72	2			0.07
14	90020626	KUMI GUMMI RUBBER GUMMI	5X40-265	L=265	4			0.07
15	90013174	KUMI GUMMI RUBBER GUMMI			2			0.02
16	90010443	KUMI GUMMI RUBBER GUMMI		L=55	2			0.01
17	3100187	LAAKERI LAGER BEARING LAGER	WB 802 8080		2			0.41
18	3010137	RUIUVI SKRUV SCREW SCHRAUBE	KKR M10X50 8.8 ZN DIN 912		6			0
19	3010685	RUIUVI SKRUV SCREW SCHRAUBE	KKR M10X25 8.8 DIN 912 ZN		12			0
20	3020004	MUTTERI MUTTER NUT MUTTER	KM M10 ZN DIN 985		6			0
21	3050003	RASVANIPPA SMÖRJNIPPEL GREASE NIPPLE SCHMIERNIPPEL	M8X1,25 DIN 71412		2			0
22	3131720	LETKU SLANG HOSE SCHLAUCH	5601-12/ HI-33-12/5660-12/L=1250		1			
23	3132308	LETKU SLANG HOSE SCHLAUCH	5601-12/ HI33-12/5601-12.L=2050		1			
24	3130357	LETKU SLANG HOSE SCHLAUCH	5201-08/ HI-98C-08/5201-08/L=1300		4			
25	3130846	LETKU SLANG HOSE SCHLAUCH	5751-08/ HI98C-08/5701-08/L=1250		2			

90022699

NOSTOPUOMI

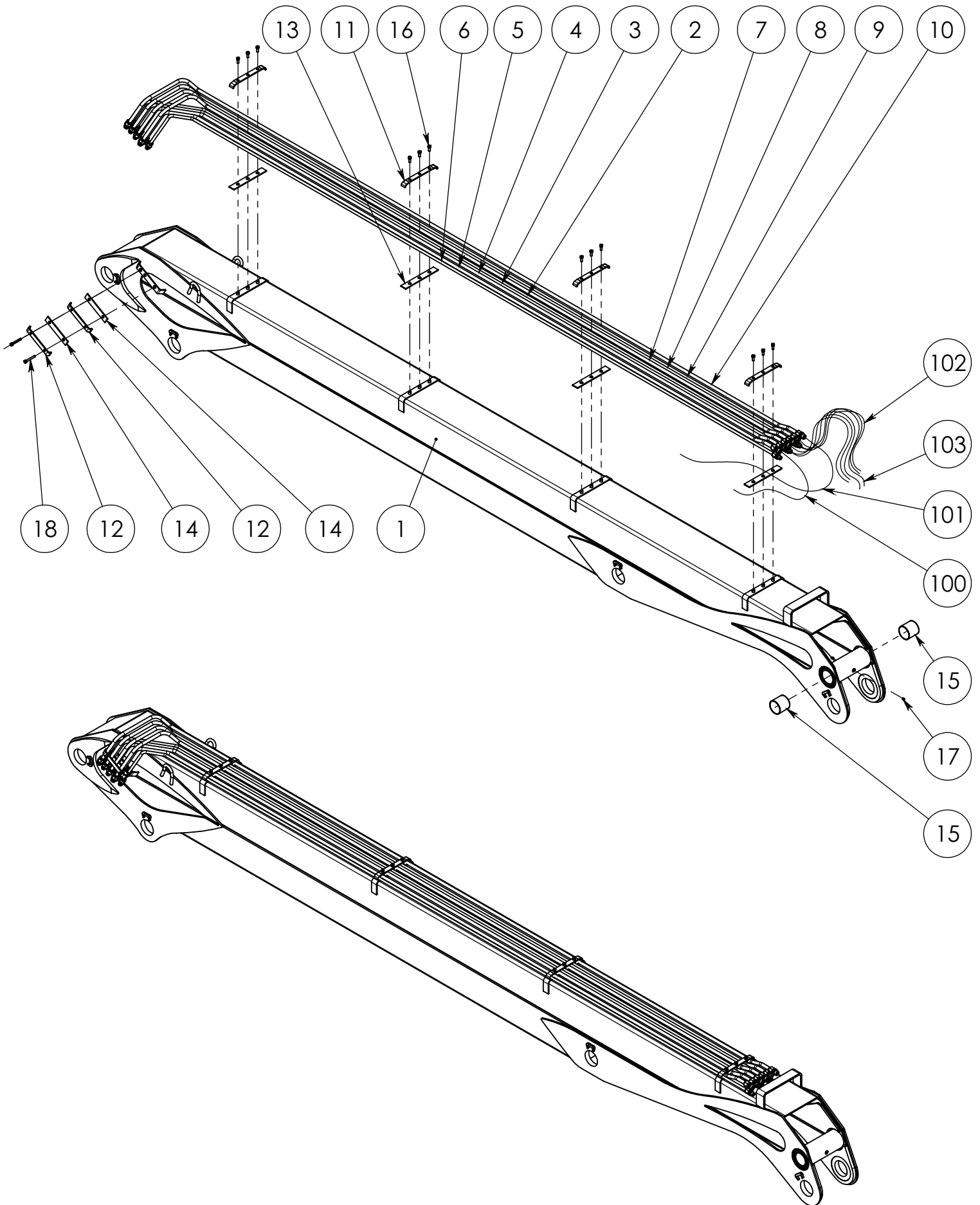



SPARE PART LIST

Item code	90022699	Revision	-
Title	LIFT BOOM	Date	18.08.2008
Specification	(5.9) HYTTIVAR		

Pos	Item code	Title	Specification	Dimensions	Pc	Amount	Unit	Nto Weight
1	90022698	LIFT BOOM	KONESTUS 2024 5.9		1			704.33
2	90022701	PIPE	1 OIKEA KOK		1			6.22
3	90022705	PIPE	2 OIKEA KOK		1			6.56
4	90022709	PIPE	3 OIKEA KOK		1			6.09
5	90022714	PIPE	4 OIKEA KOK		1			6.12
6	90022718	PIPE	5 OIKEA KOK		1			4.24
7	90022703	PIPE	1 VASEN (HYTTI) KOK		1			6.72
8	90022707	PIPE	2 VASEN (HYTTI) KOK		1			6.75
9	90022711	PIPE	3 VASEN (HYTTI) KOK		1			6.76
10	90022716	PIPE	4 VASEN (HYTTI) KOK		1			6.89
11	90020625	FASTENER	6X30-284	L=284	4			0.38
12	90022330	FASTENER	6X30-250	L=215	2			0.3
13	90020626	RUBBER	5X40-265	265x40	4			0.07
14	90021961	RUBBER	5X40-190	190x40	2			
15	3100187	BEARING	WB 802 8080		2			0.41
16	3010685	SCREW	KKR M10X25 8.8 DIN 912 ZN		12			0
17	3050003	GREASE NIPPLE	M8X1,25 DIN 71412		2			0
18	3010274	SCREW	KKR M10 X 70 8.8 ZN DIN 912		2			0
100	3131720	HOSE	5601-12/ HI-33-12/5660-12/L=1250		1			
101	3132308	HOSE	5601-12/HI33-12/5601-12.L=2050		1			
102	3130357	HOSE	5201-08/HI+98C-08/5201-08/L=1300		4			
103	3130846	HOSE	5751-08/HI98C-08/5701-08/L=1250		2			

90022451

NOSTOPUOMI

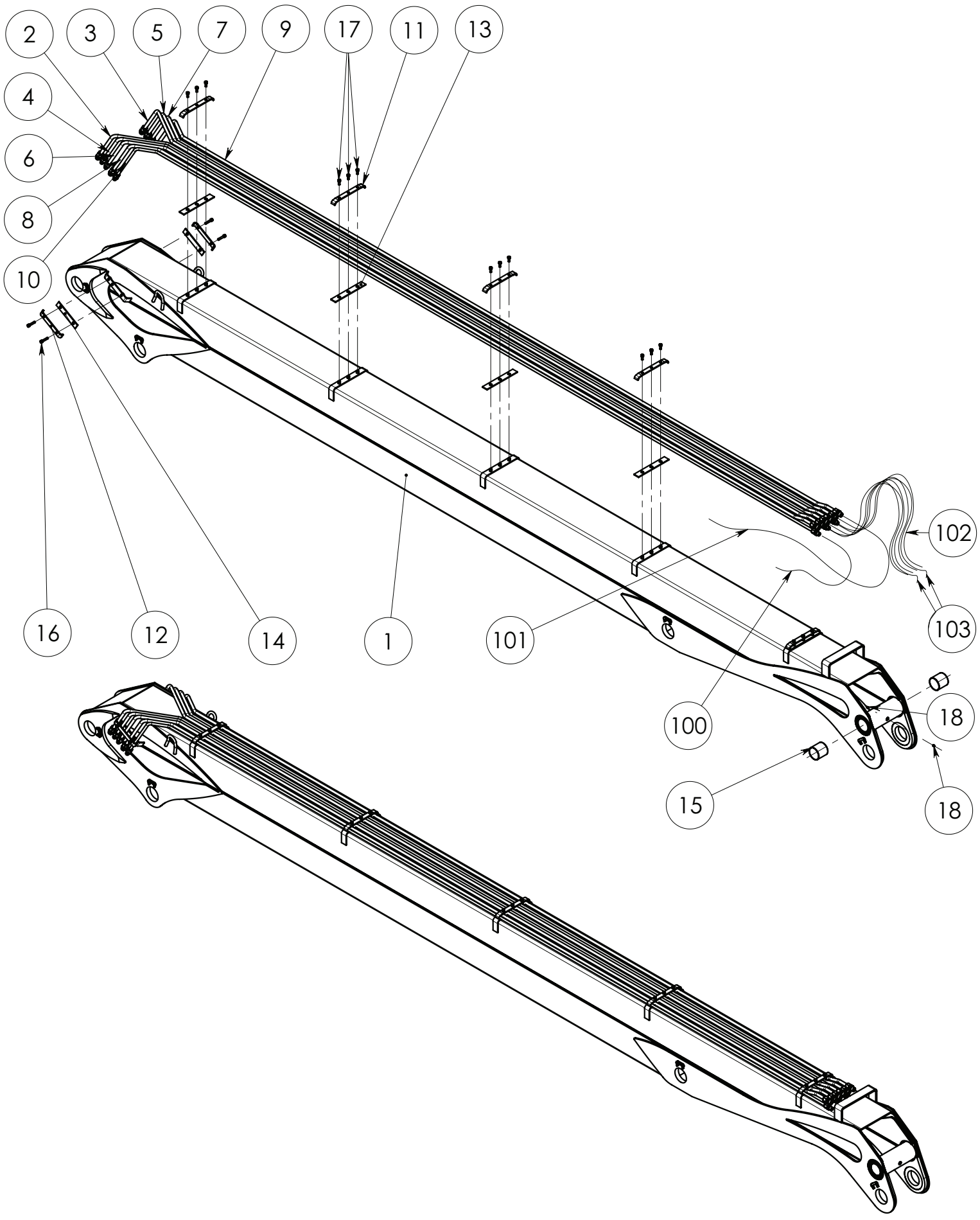



SPARE PART LIST

Item code	90022451	Revision	-
Title	NOSTOPUOMI	Date	19.03.2008
Specification	(6.9) VAR		

Pos	Item code	Title	Specification	Dimensions	Pc	Amount	Unit	Nto Weight
1	90022359	NOSTOPUOMI LYFTBOM LIFT BOOM HUBARM	KONESTUS 6.9		1			795.33
2	90022368	PUTKI RÖR PIPE ROHR	1 OIKEA KOK		1			7.3
3	90022374	PUTKI RÖR PIPE ROHR	1 VASEN KOK		1			7.7
4	90022376	PUTKI RÖR PIPE ROHR	2 OIKEA KOK		1			7.64
5	90022407	PUTKI RÖR PIPE ROHR	2 VASEN KOK		1			7.64
6	90022415	PUTKI RÖR PIPE ROHR	3 OIKEA KOK		1			7.17
7	90022421	PUTKI RÖR PIPE ROHR	3 VASEN KOK		1			7.58
8	90022432	PUTKI RÖR PIPE ROHR	4 OIKEA KOK		1			7.2
9	90022434	PUTKI RÖR PIPE ROHR	4 VASEN KOK		1			7.59
10	90022439	PUTKI RÖR PIPE ROHR	5 OIKEA (SÄHKÖ) KOK		1			4.93
11	90020625	KIINNIKE FÄSTE FASTENER BEFESTIGUNG	6X30-284	L=284	5			0.38
12	90022330	KIINNIKE FÄSTE FASTENER BEFESTIGUNG	6X30-250	L=215	2			0.3
13	90020626	KUMI GUMMI RUBBER GUMMI	5X40-265	265x40	5			0.07
14	90021961	KUMI GUMMI RUBBER GUMMI	5X40-190	190x40	2			
15	3100187	LAAKERI LAGER BEARING LAGER	WB 802 8080		2			0.41
16	3010137	RUUVI SKRUV SCREW SCHRAUBE	KKR M10X50 8.8 ZN DIN 912		4			0
17	3010685	RUUVI SKRUV SCREW SCHRAUBE	KKR M10X25 8.8 DIN 912 ZN		15			0
18	3050003	RASVANIPPA SMÖRJNIPPEL GREASE NIPPLE SCHMIERNIPPEL	M8X1,25 DIN 71412		2			0
100	3131720	LETKU SLANG HOSE SCHLAUCH	5601-12/ HI-33-12/5660-12/L=1250		1			
101	3132308	LETKU SLANG HOSE SCHLAUCH	5601-12/ HI33-12/5601-12.L=2050		1			
102	3130357	LETKU SLANG HOSE SCHLAUCH	5201-08/ HI-98C-08/5201-08/L=1300		4			
103	3130846	LETKU SLANG HOSE SCHLAUCH	5751-08/ HI98C-08/5701-08/L=1250		2			

90022647

NOSTOPUOMI

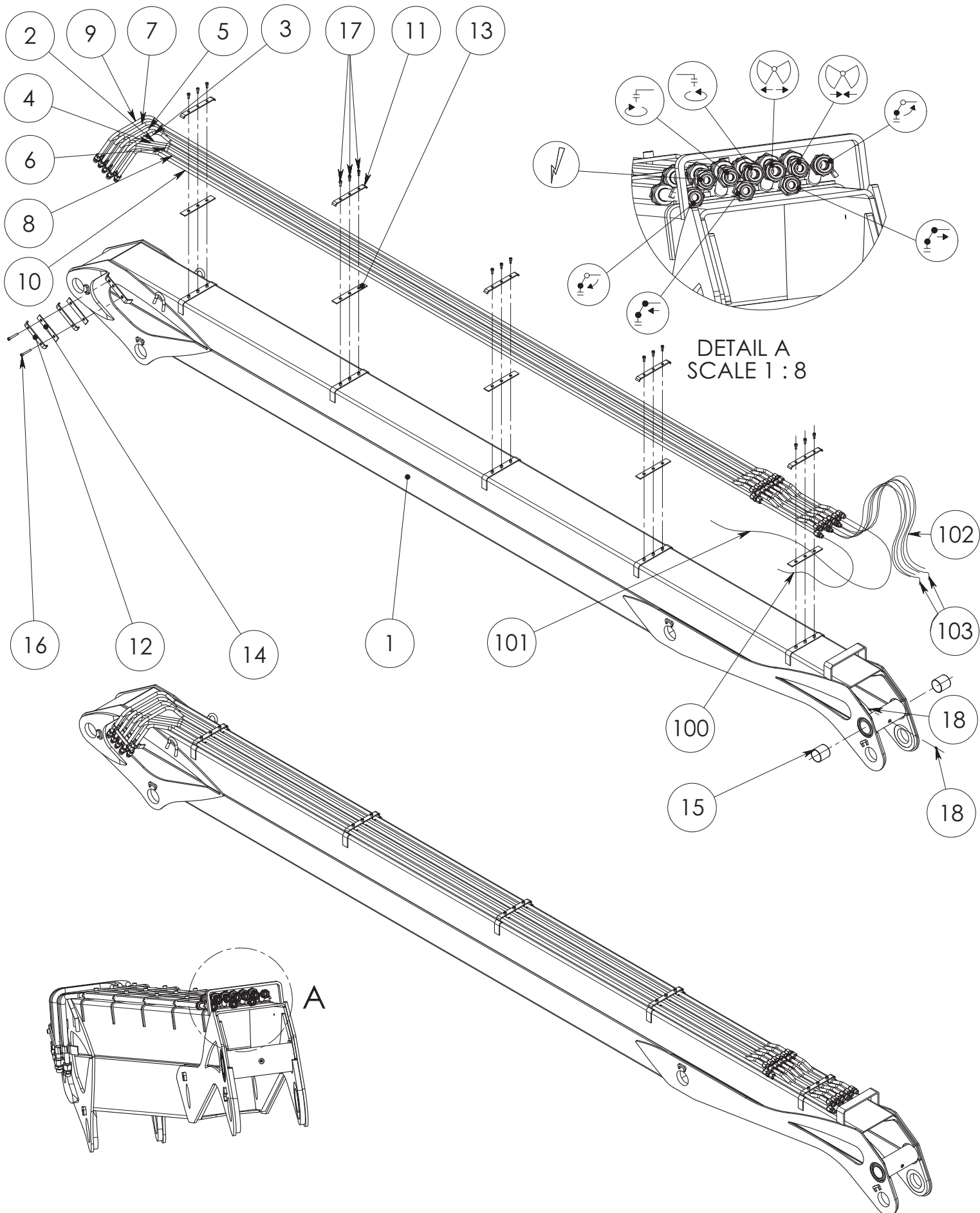



SPARE PART LIST

Item code	90022647	Revision	-
Title	NOSTOPUOMI	Date	01.07.2008
Specification	(6.9) HYTTIVAR		

Pos	Item code	Title	Specification	Dimensions	Pc	Amount	Unit	Nto Weight
1	90022359	NOSTOPUOMI LYFTBOM LIFT BOOM HUBARM	KONESTUS 6.9		1			795.41
2	90022368	PUTKI RÖR PIPE ROHR	1 OIKEA KOK		1			7.62
3	90022646	PUTKI RÖR PIPE ROHR	1 VASEN (HYTTI) KOK		1			8.52
4	90022376	PUTKI RÖR PIPE ROHR	2 OIKEA KOK		1			8.34
5	90022649	PUTKI RÖR PIPE ROHR	2 VASEN (HYTTI) KOK		1			8.53
6	90022415	PUTKI RÖR PIPE ROHR	3 OIKEA KOK		1			7.49
7	90022652	PUTKI RÖR PIPE ROHR	3 VASEN (HYTTI) KOK		1			8.56
8	90022432	PUTKI RÖR PIPE ROHR	4 OIKEA KOK		1			7.51
9	90022657	PUTKI RÖR PIPE ROHR	4 VASEN (HYTTI) KOK		1			7.89
10	90022439	PUTKI RÖR PIPE ROHR	5 OIKEA (SÄHKÖ) KOK		1			5.41
11	90020625	KIINNIKE FÄSTE FASTENER BEFESTIGUNG	6X30-284	L=284	5			0.38
12	90022330	KIINNIKE FÄSTE FASTENER BEFESTIGUNG	6X30-250	L=215	2			0.3
13	90020626	KUMI GUMMI RUBBER GUMMI	5X40-265	265x40	5			0.07
14	90021961	KUMI GUMMI RUBBER GUMMI	5X40-190	190x40	2			
15	3100187	LAAKERI LAGER BEARING LAGER	WB 802 8080		2			0.41
16	3010274	RUIVI SKRUV SCREW SCHRAUBE	KKR M10 X 70 8.8 ZN DIN 912		2			0
17	3010685	RUIVI SKRUV SCREW SCHRAUBE	KKR M10X25 8.8 DIN 912 ZN		15			0
18	3050003	RASVANIPPA SMÖRJNIPPEL GREASE NIPPLE SCHMIERNIPPEL	M8X1,25 DIN 71412		2			0
100	3131720	LETKU SLANG HOSE SCHLAUCH	5601-12/ HI-33-12/5660-12/L=1250		1			
101	3132308	LETKU SLANG HOSE SCHLAUCH	5601-12/HI33-12/5601-12.L=2050		1			
102	3130357	LETKU SLANG HOSE SCHLAUCH	5201-08/HI-98C-08/5201-08/L=1300		4			
103	3130846	LETKU SLANG HOSE SCHLAUCH	5751-08/HI98C-08/5701-08/L=1250		2			

90020589

PUOMI 4.2m

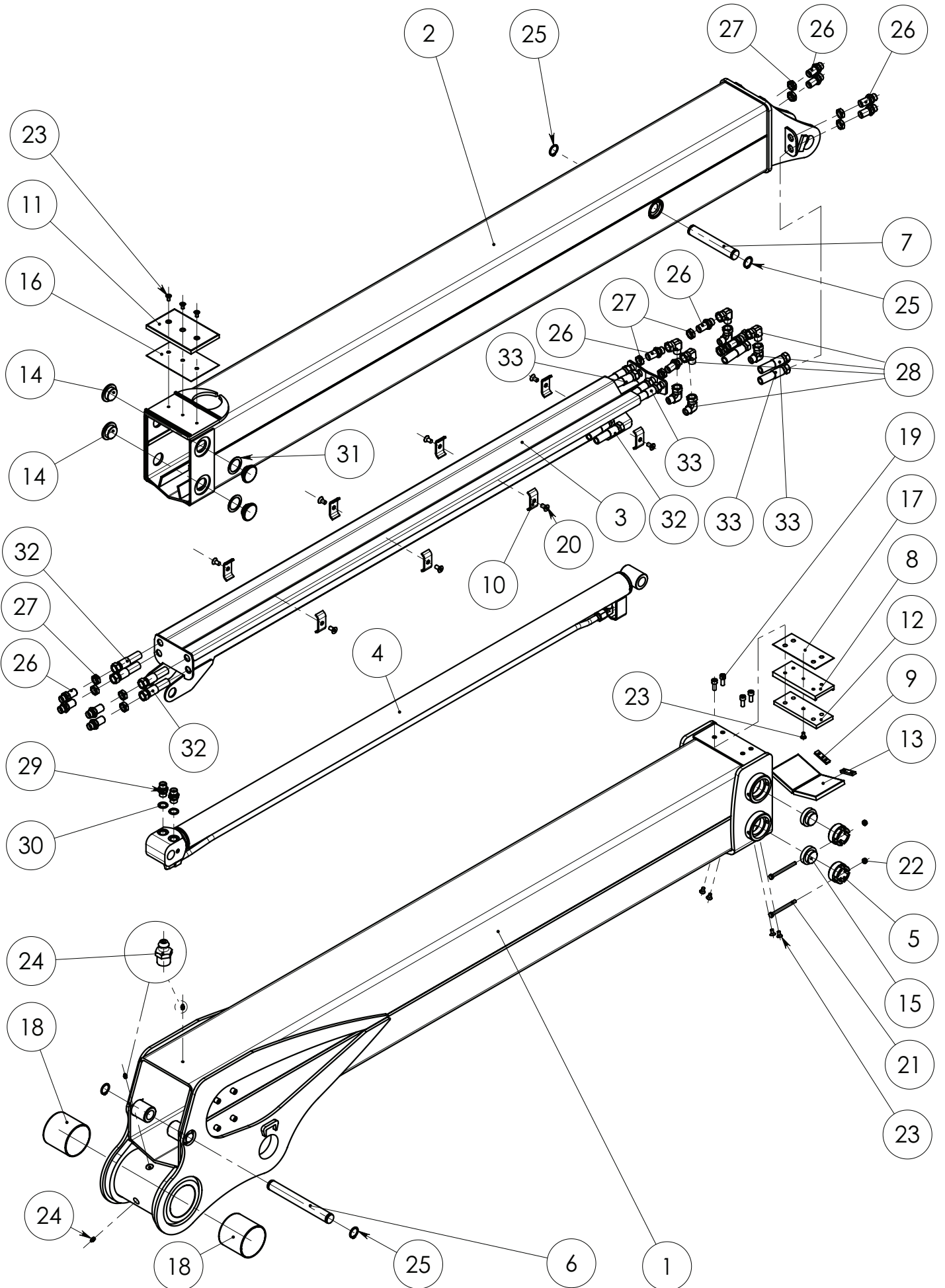

Item code	90020589	Revision	-
Title	PUOMI	Date	12.05.2005
Specification	1-JATK. VAR 4.2		

Pos	Item code	Title	Specification	Dimensions	Pc	Amount	Unit	Nto Weight
1	90020522	PUOMI BOM BOOM ARM	[2.5] KONEISTUS		1			230.72
2	90020546	JATKE UTSKJUT EXTENSION AUSSCHUB	2.6 HITSAAUS		1			127.6
3	90020575	OHJAIN STYRNING GUIDANCE STEUERUNG			1			18.87
4	28764001	SYLINTERI CYLINDER CYLINDER ZYLINDER	63/36 X 1700		1			40.13
5	90016090	KIINNIKE FÄSTE FASTENER BEFESTIGUNG		L=37	4			0.35
6	90020554	AKSELI AXEL AXLE AXHSE	30X254	L=124	1			1.4
7	90020555	AKSELI AXEL AXLE AXHSE	30X188	L=124	1			1.04
8	90020556	KIINNIKE FÄSTE FASTENER BEFESTIGUNG	L-180	L=182	1			1.18
9	90010345	PIDIKE FÄSTE HOLDER GESTELL		52x15	2			0.03
10	90010442	KIINNIKE FÄSTE FASTENER BEFESTIGUNG	LT4X30-72	L=72	8			0.07
11	90020561	LIUKUPALA GLIDKLACK GLIDE PAD GLEITLAGER	120X190	190X120	1			0.31
12	90020563	LIUKUPALA GLIDKLACK GLIDE PAD GLEITLAGER	70X180	180X70	1			0.17
13	90020562	LIUKUPALA GLIDKLACK GLIDE PAD GLEITLAGER	120X100	100X120	2			0.17
14	90011001	LIUKUPALA GLIDKLACK GLIDE PAD GLEITLAGER	OILON D=55-19/7	L=32	4			0.04
15	90021097	LIUKUPALA GLIDKLACK GLIDE PAD GLEITLAGER	40X55-14X12	32x55	4			0.06
16	90020566	LEVY PLÅT PLATE PLATTE	119X190	190X119	1			
17	90020567	LEVY PLÅT PLATE PLATTE	80X180	180X80	1			
18	3100176	LAAKERI LAGER BEARING LAGER	WB 802 10095		2			0.6
19	3010685	RUUVI SKRUV SCREW SCHRAUBE	KKR M10X25 8.8 DIN 912 ZN		4			0
20	3010247	RUUVI SKRUV SCREW SCHRAUBE	KKR 10X20 10.9 DIN 7991		8			0
21	3010447	RUUVI SKRUV SCREW SCHRAUBE	KR M8 X 100 8.8 ZN DIN 931		4			0
22	3020001	MUTTERI MUTTER NUT MUTTER	KM M8 ZN DIN 985		4			0
23	3010190	RUUVI SKRUV SCREW SCHRAUBE	KKR M8X16 10.9 DIN 7991		8			0
24	3050003	RASVANIPPA SMÖRJNIPPEL GREASE NIPPLE SCHMIERNIPPEL	M8X1.25 DIN 71412		3			0
25	3060092	PIDÄTINRENGAS LÅSRING SNAPRING SPRENGRING	AS30X2 DIN 471		4			0
26	3090297	LIITIN KOPPLINGSSTYCKE CONNECTOR KONNEKTOR	04000-08 EP		12			0.12
27	3090300	MUTTERI MUTTER NUT MUTTER	1270-08 ZN (R1/2")		12			0.02
28	3090670	LIITIN KOPPLINGSSTYCKE CONNECTOR KONNEKTOR	04510-08		8			0.21
29	3090019	LIITIN KOPPLINGSSTYCKE CONNECTOR KONNEKTOR	04000-08 (R1/2")		2			0.1
30	3110042	TIIVISTE TÄTNING SEAL DICHTUNG	USIT R-08 (R1/2")		2			0.01
31	21039422	ALUSLEVY BRICKA WASHER UNTERLEGSCHEIBE	1XD=55	55x55	4			0.01
32	3130739	LETKU SLANG HOSE SCHLAUCH	5201-08/HI98C-08/5201-08 L=2000		4			0.48
33	3132307	LETKU SLANG HOSE SCHLAUCH	5701-08/241X-08/5701-08 L=2840		4			0

90020865
PUOMI 5.4m

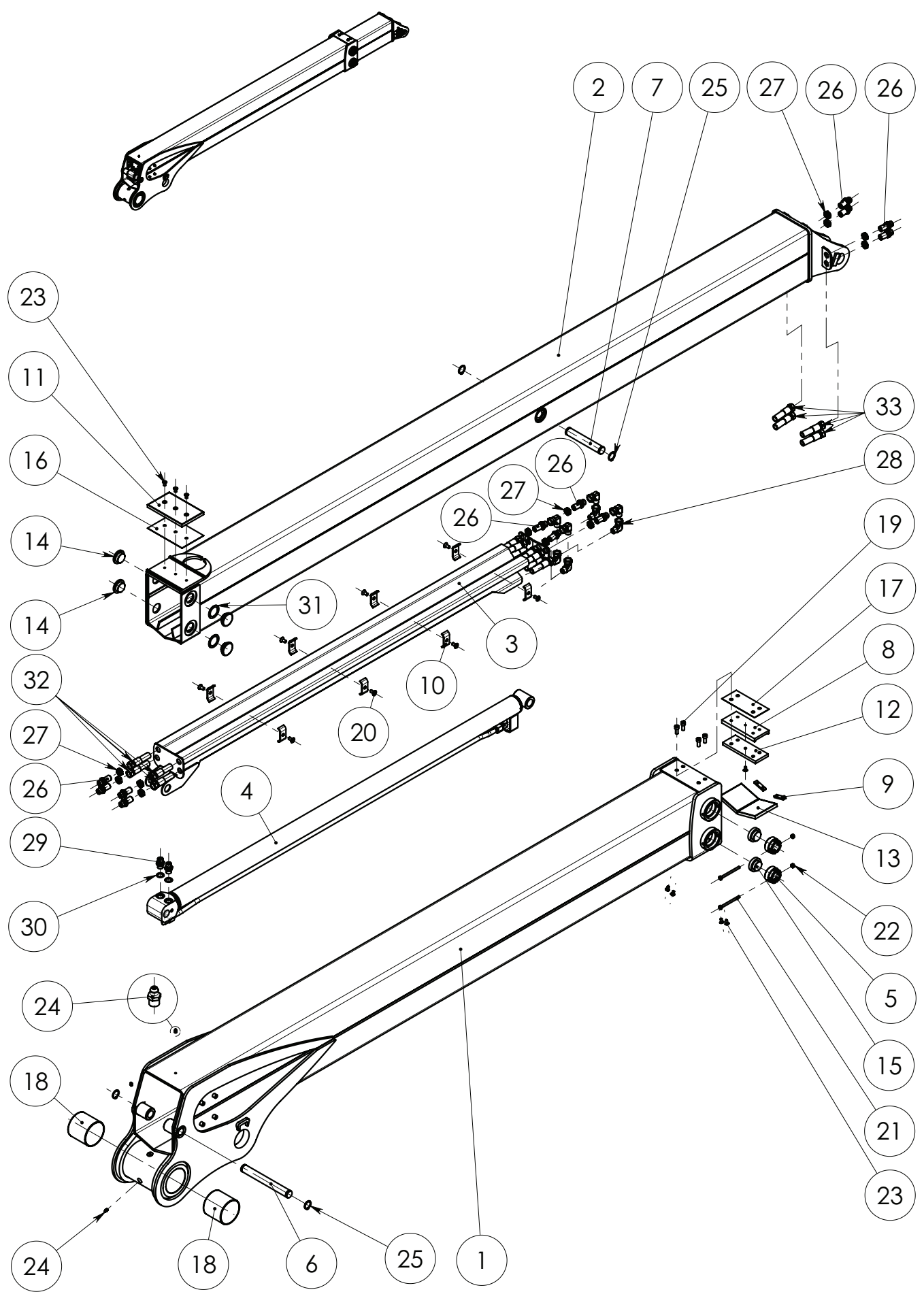



SPARE PART LIST

Item code	90020865	Revision	-
Title	PUOMI	Date	29.09.2005
Specification	1-JATK. (5.4) VAR		

Pos	Item code	Title	Specification	Dimensions	Pc	Amount	Unit	Nto Weight
1	90020864	PUOMI BOM BOOM ARM	{3.0} KONEISTUS		1			260.78
2	90020858	JATKE UTSKJUT EXTENSION AUSSCHUB	3.6 HITSAAUS		1			170.42
3	90020575	OHJAIN STYRNING GUIDANCE STEUERUNG			1			18.87
4	28764001	SYLINTERI CYLINDER CYLINDER ZYLINDER	63/36 X 1700		1			40.13
5	90016090	KIINNIKE FÄSTE FASTENER BEFESTIGUNG		L=37	4			0.35
6	90020554	AKSELI AXEL AXLE AXHSE	30X254	L=124	1			1.4
7	90020555	AKSELI AXEL AXLE AXHSE	30X188	L=124	1			1.04
8	90020556	KIINNIKE FÄSTE FASTENER BEFESTIGUNG	L-180	L=182	1			1.18
9	90010345	PIDIKE FÄSTE HOLDER GESTELL		52x15	2			0.03
10	90010442	KIINNIKE FÄSTE FASTENER BEFESTIGUNG	LT4X30-72	L=72	8			0.07
11	90020561	LIUKUPALA GLIDKLACK GLIDE PAD GLEITLAGER	120X190	190x120	1			0.31
12	90020563	LIUKUPALA GLIDKLACK GLIDE PAD GLEITLAGER	70X180	180x70	1			0.17
13	90020562	LIUKUPALA GLIDKLACK GLIDE PAD GLEITLAGER	120X100	100x120	2			0.17
14	90011001	LIUKUPALA GLIDKLACK GLIDE PAD GLEITLAGER	OILON D=55-19/7	L=32	4			0.04
15	90021097	LIUKUPALA GLIDKLACK GLIDE PAD GLEITLAGER	40X55-14X12	L=32	4			0.06
16	90020566	LEVY PLÅT PLATE PLATTE	119X190	190x119	1			
17	90020567	LEVY PLÅT PLATE PLATTE	80X180	180x80	1			
18	3100176	LAAKERI LAGER BEARING LAGER	WB 802 10095		2			0.6
19	3010685	RUUVI SKRUV SCREW SCHRAUBE	KKR M10X25 8.8 DIN 912 ZN		4			0
20	3010247	RUUVI SKRUV SCREW SCHRAUBE	KKR 10X20 10.9 DIN 7991		8			0
21	3010447	RUUVI SKRUV SCREW SCHRAUBE	KR M8 X 100 8.8 ZN DIN 931		4			0
22	3020001	MUTTERI MUTTER NUT MUTTER	KM M8 ZN DIN 985		4			0
23	3010190	RUUVI SKRUV SCREW SCHRAUBE	KKR M8X16 10.9 DIN 7991		8			0
24	3050003	RASVANIPPA SMÖRJNIPPEL GREASE NIPPLE SCHMIERNIPPEL	M8X1.25 DIN 71412		3			0
25	3060092	PIDÄTINRENGAS LÅSRING SNAPRING SPRENGRING	AS30X2 DIN 471		4			0
26	3090297	LIITIN KOPPLINGSSTYCKE CONNECTOR KONNEKTOR	04000-08 EP		12			0.12
27	3090300	MUTTERI MUTTER NUT MUTTER	1270-08 ZN (R1/2")		12			0.02
28	3090670	LIITIN KOPPLINGSSTYCKE CONNECTOR KONNEKTOR	04510-08		8			0.21
29	3090019	LIITIN KOPPLINGSSTYCKE CONNECTOR KONNEKTOR	04000-08 (R1/2")		2			0.1
30	3110042	TIIVISTE TÄTNING SEAL DICHTUNG	USIT R-08 (R1/2")		2			0.01
31	21039422	ALUSLEVY BRICKA WASHER UNTERLEGSCHEIBE	1XD=55	55x55	4			0.01
32	3130739	LETKU SLANG HOSE SCHLAUCH	5201-08/HI98C-08/5201-08 L=2000		4			0.48
33	3132454	LETKU SLANG HOSE SCHLAUCH	5701-08/241X-08/5701-08 L=3840		4			

90022519
PUOMI 5.7m

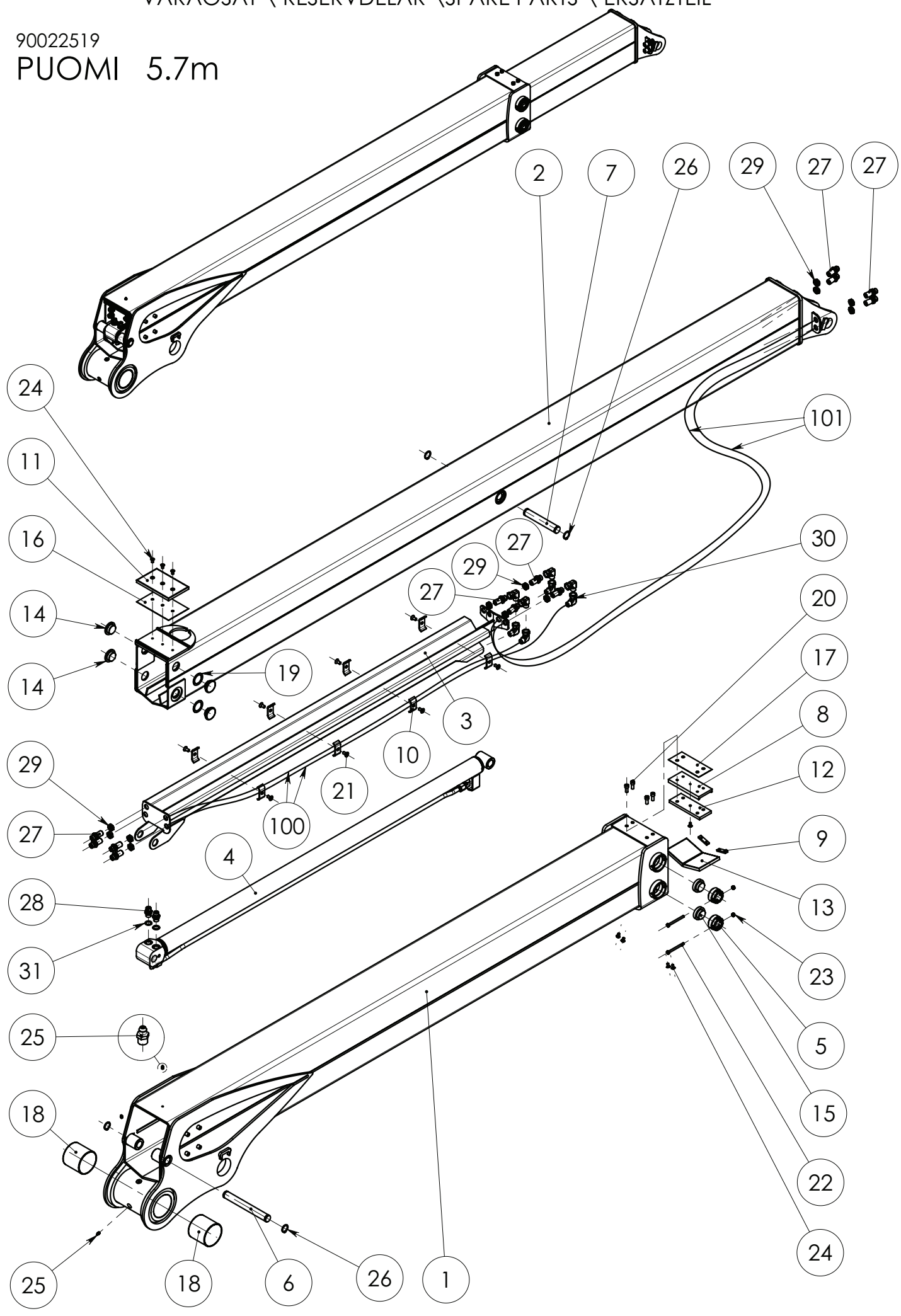



SPARE PART LIST

Item code	90022519	Revision	-
Title	PUOMI	Date	29.04.2008
Specification	1-JATK. (5.7) VAR		

Pos	Item code	Title	Specification	Dimensions	Pc	Amount	Unit	Nto Weight
1	90020864	PUOMI BOM BOOM ARM	{3.0} KONEISTUS		1			261.75
2	90022513	JATKE UTSKJUT EXTENSION AUSSCHUB	3.9 HITSAAUS		1			183.23
3	90020575	OHJAIN STYRNING GUIDANCE STEUERUNG			1			18.87
4	28764001	SYLINTERI CYLINDER CYLINDER ZYLINDER	63/36 X 1700		1			40.12
5	90016090	KIINNIKE FÄSTE FASTENER BEFESTIGUNG		L=37	4			0.35
6	90020554	AKSELI AXEL AXLE AXHSE	30X254	L=98	1			1.4
7	90020555	AKSELI AXEL AXLE AXHSE	30X188	L=98	1			1.04
8	90020556	KIINNIKE FÄSTE FASTENER BEFESTIGUNG	L-180	L=182	1			1.18
9	90010345	PIDIKE FÄSTE HOLDER GESTELL		52x15	2			0.03
10	90010442	KIINNIKE FÄSTE FASTENER BEFESTIGUNG	LT4X30-72	L=72	8			0.07
11	90020561	LIUKUPALA GLIDKLACK GLIDE PAD GLEITLAGER	120X190	190x120	1			0.31
12	90020563	LIUKUPALA GLIDKLACK GLIDE PAD GLEITLAGER	70X180	180x70	1			0.17
13	90020562	LIUKUPALA GLIDKLACK GLIDE PAD GLEITLAGER	120X100	100x120	2			0.17
14	90011001	LIUKUPALA GLIDKLACK GLIDE PAD GLEITLAGER	D=55-19/7	L=20	4			0.03
15	90021097	LIUKUPALA GLIDKLACK GLIDE PAD GLEITLAGER	40X55-14X12	L=20	4			0.06
16	90020566	LEVY PLÁT PLATE PLATTE	119X190	190x119	1			
17	90020567	LEVY PLÁT PLATE PLATTE	80X180	180x80	1			
18	3100176	LAAKERI LAGER BEARING LAGER	WB 802 10095		2			0.6
19	21039422	ALUSLEVY BRICKA WASHER UNTERLEGSCHEIBE	1XD=55	55x55	2			0.01
20	3010685	RUUVI SKRUV SCREW SCHRAUBE	KKR M10X25 8.8 DIN 912 ZN		4			0
21	3010247	RUUVI SKRUV SCREW SCHRAUBE	KKR 10X20 10.9 DIN 7991		8			0
22	3010328	RUUVI SKRUV SCREW SCHRAUBE	KR M8 X 90 8.8 ZN DIN 931		4			0
23	3020001	MUTTERI MUTTER NUT MUTTER	KM M8 ZN DIN 985		4			0
24	3010190	RUUVI SKRUV SCREW SCHRAUBE	KKR M8X16 10.9 DIN 7991		8			0
25	3050003	RASVANIPPA SMÖRJNIPPEL GREASE NIPPLE SCHMIERNIPPEL	M8X1.25 DIN 71412		3			0
26	3060092	PIDÄTINRENGAS LÄSRING SNAPRING SPRENGRING	A530X2 DIN 471		4			0
27	3090297	LIITIN KOPPLINGSSTYCKE CONNECTOR KONNEKTOR	04000-08 EP		12			0.12
28	3090019	LIITIN KOPPLINGSSTYCKE CONNECTOR KONNEKTOR	04000-08 (R1/2")		2			0.1
29	3090300	MUTTERI MUTTER NUT MUTTER	1270-08 ZN (R1/2")		12			0.02
30	3090670	LIITIN KOPPLINGSSTYCKE CONNECTOR KONNEKTOR	04510-08		8			0.21
31	3110042	TIVISTE TÄTNING SEAL DICHTUNG	USIT R-08 (R1/2")		2			0.01
100	3130739	LETKU SLANG HOSE SCHLAUCH	5201-08/Hi98C-08/5201-08 L=2000		4			0.48
101	3131807	LETKU SLANG HOSE SCHLAUCH	5701-08/ HI 84-08/5701-08, L=4100		4			

90020495
TANKO

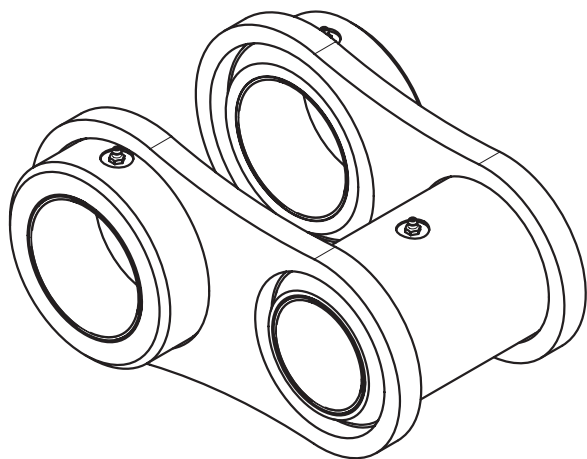
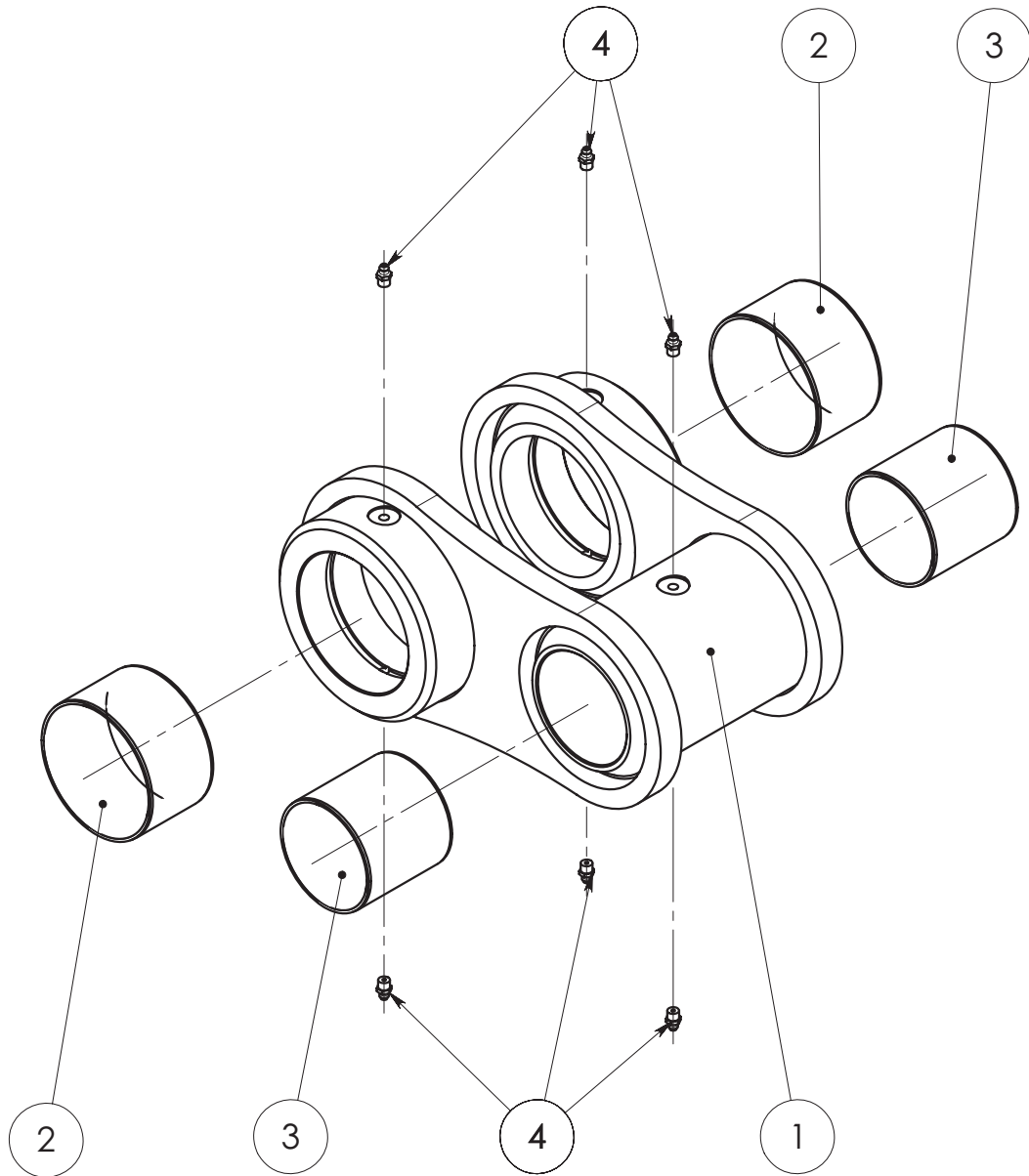



SPARE PART LIST

Item code	90020495	Revision	-
Title	TANKO	Date	24.05.2005
Specification	VAR		

Pos	Item code	Title	Specification	Dimensions	Pc	Amount	Unit	Nto Weight
1	90020437	TANKO LÄNK LINK GELENK	KONESTUS		1			20.37
2	3100344	LAAKERI LAGER BEARING LAGER	WB 802 10060		2			0.38
3	3100187	LAAKERI LAGER BEARING LAGER	WB 802.8080		2			0.41
4	3050003	RASVANIPPA SMÖRJNIPPEL GREASE NIPPLE SCHMIERNIPPEL	M8X1,25 DIN 71412		6			0

min 1215 max 2070

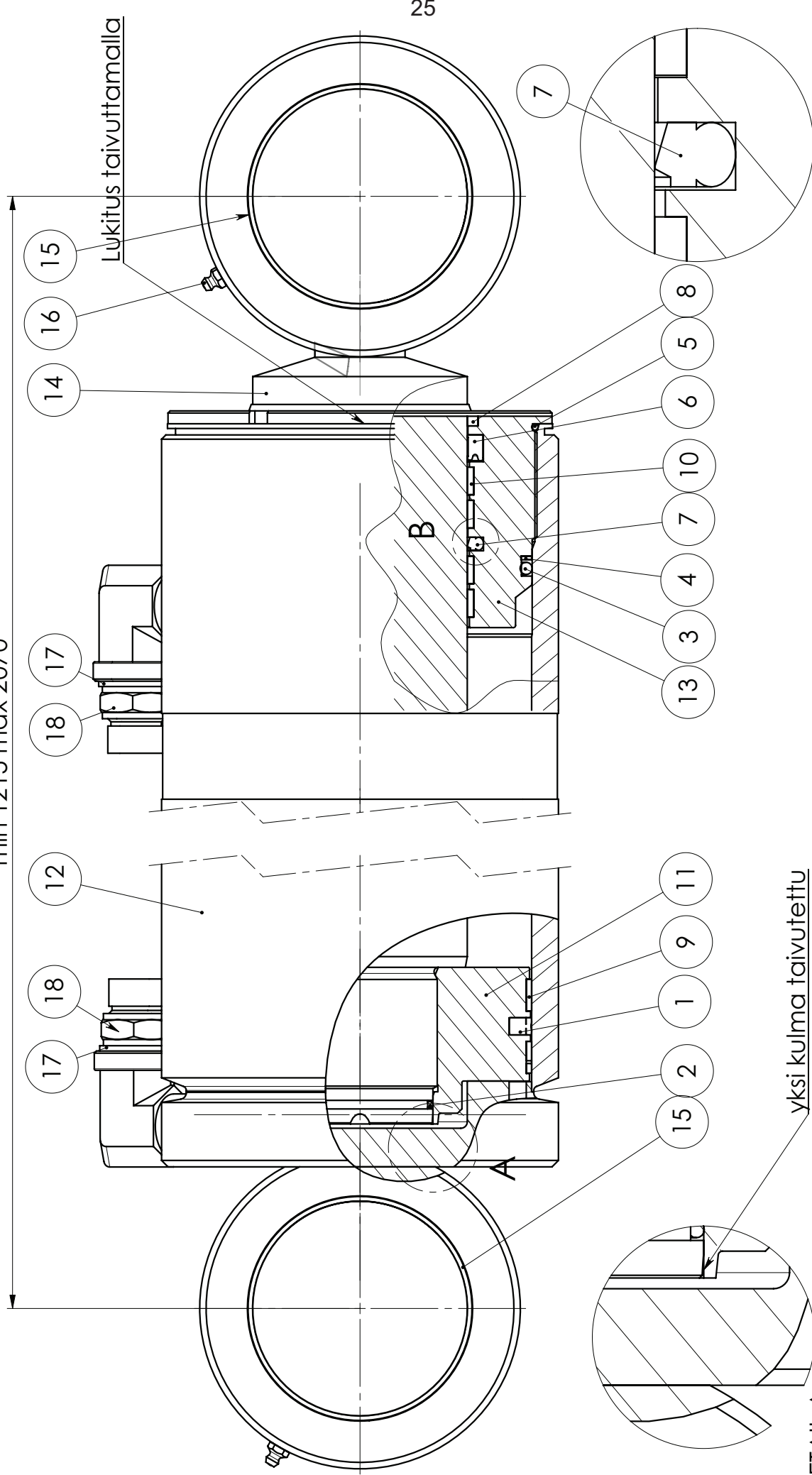

DETAIL A
SCALE 1:1

DETAIL B
SCALE 2:1

yksi kulma taivutettu

Lukitus taivuttamalla

NOSTO-
SYLINTERI

28762001



SPARE PART LIST

Item code	28762001	Revision	-
Title	SYLINTERI	Date	15.02.2005
Specification	160/100 X 855 (NOSTO)		

Pos	Item code	Title	Specification	Dimensions	Pc	Amount	Unit	Nto Weight
1	3110790	TIIVISTE TÄTNIING SEAL DICHTUNG	OK 160/139X8		1			0.3
2	3110250	TIIVISTE TÄTNIING SEAL DICHTUNG	O 62.2 X 3 90 SH		1			0.01
3	3110791	TIIVISTE TÄTNIING SEAL DICHTUNG	O 149.2X5.7 70 SHORE		1			0.1
4	3110792	TIIVISTE TÄTNIING SEAL DICHTUNG	TR 160/150 X 1.7 PU		1			0
5	3110454	TIIVISTE TÄTNIING SEAL DICHTUNG	O 160 X 3.0 90 SHORE		1			0.03
6	3110726	TIIVISTE TÄTNIING SEAL DICHTUNG	100/115 X 12		1			0.2
7	3110885	TIIVISTE TÄTNIING SEAL DICHTUNG	VARREN TIIV. OMS-MR 100/115,1X6		1			0.1
8	3110414	TIIVISTE TÄTNIING SEAL DICHTUNG	GA 100X110X7/10		1			0.1
9	3110865	OHJAIN STYRNING GUIDANCE STEUERUNG	160/155 X 14.8 KUDOSBAK.		2			0.14
10	3110866	OHJAIN STYRNING GUIDANCE STEUERUNG	100/106 X 12.8 KUDOSBAK.		4			0.1
11	28762201	MÄNTÄ KOLV PISTON KOLBEN	160	L=77	1			6.49
12	28762101	SYLINTERIPUTKI CYLINDERROHR	Ø160/100 X 855		1			73.24
13	28762202	OHJAIN STYRNING GUIDANCE STEUERUNG	160/100	L=105	1			8.9
14	28762204	MÄNNÄNVARSI KOLVSTÄNG PISTON ROD KOLBENSTANGE	160 / 100 X 855		1			77.29
15	3100344	LAAKERI LAGER BEARING LAGER	WB 802 10060		4			0.38
16	3050003	RASVANIPPA SMÖRJNIPPEL GREASE NIPPLE SCHMIERNIPPEL	M8X1,25 DIN 71412		4			0
20	3110130	TIIVISTE TÄTNIING SEAL DICHTUNG	USIT R-12 (R3/4")		2			0.01
21	3090185	LIITIN KOPPLINGSSTYCKE CONNECTOR KONNEKTOR	O4000-12		2			0.14
-10	3110867	TIIVISTE	TIIVISTE SRJ 160/100		1			1

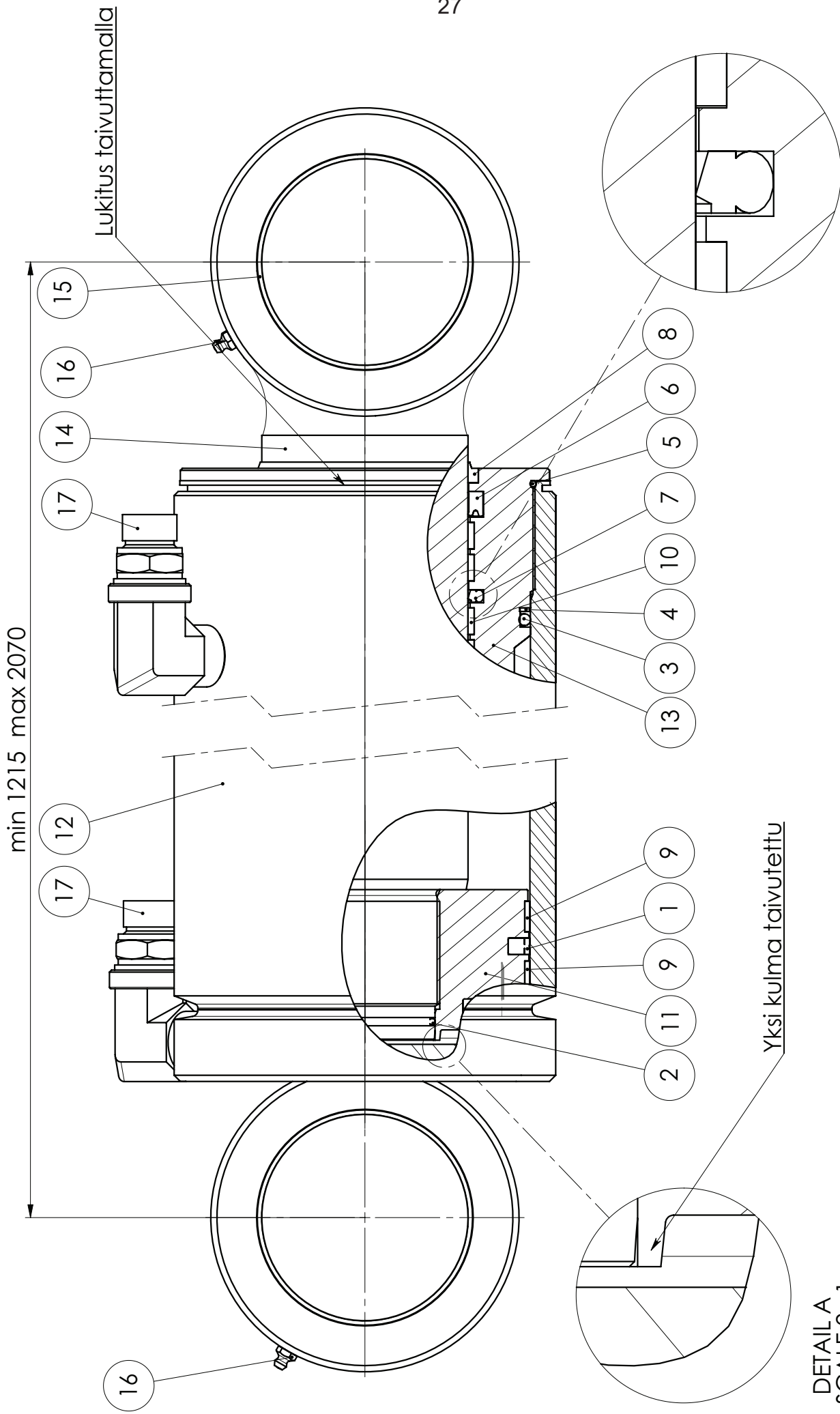

DETAIL A
SCALE 2:1

SIIRTO-

SYLINTERI

28763001



SPARE PART LIST

Item code	28763001	Revision	-
Title	SYLINTERI	Date	21.02.2005
Specification	160/100 X 855 (SIIRTO)		

Pos	Item code	Title	Specification	Dimensions	Pc	Amount	Unit	Nto Weight
1	3110790	TIIVISTE TÄTNIING SEAL DICHTUNG	OK 160/139X8		1			0.3
2	3110250	TIIVISTE TÄTNIING SEAL DICHTUNG	O 62.2 X 3 90 SH		1			0.01
3	3110791	TIIVISTE TÄTNIING SEAL DICHTUNG	O 149.2X5.7 70 SHORE		1			0.1
4	3110792	TIIVISTE TÄTNIING SEAL DICHTUNG	TR 160/150 X 1.7 PU		1			0
5	3110454	TIIVISTE TÄTNIING SEAL DICHTUNG	O 160 X 3.0 90 SHORE		1			0.03
6	3110726	TIIVISTE TÄTNIING SEAL DICHTUNG	100/115 X 12		1			0.2
7	3110885	TIIVISTE TÄTNIING SEAL DICHTUNG	VARREN TIIV. OMS-MR 100/115,1X6		1			0.1
8	3110414	TIIVISTE TÄTNIING SEAL DICHTUNG	GA 100X110X7/10		1			0.1
9	3110865	OHJAIN STYRNING GUIDANCE STEUERUNG	160/155 X 14.8 KUDOSBAK.		2			0.14
10	3110866	OHJAIN STYRNING GUIDANCE STEUERUNG	100/106 X 12.8 KUDOSBAK.		4			0.1
11	28762201	MÄNTÄ KOLV PISTON KOLBEN	160	L=77	1			6.49
12	28763101	SYLINTERIPUTKI CYLINDERROHR	Ø160/100 X 855		1			73.24
13	28762202	OHJAIN STYRNING GUIDANCE STEUERUNG	160/100	L=105	1			8.9
14	28763204	MÄNNÄNVARSI KOLVSTÄNG PISTON ROD KOLBENSTANGE	160 / 100 X 855		1			72.54
15	3100344	LAAKERI LAGER BEARING LAGER	WB 802 10060		4			0.38
16	3050003	RASVANIPPA SMÖRJNIPPEL GREASE NIPPLE SCHMIERNIPPEL	M8X1,25 DIN 71412		4			0
17	3090185	LIITIN KOPPLINGSSTYCKE CONNECTOR KONNEKTOR	O4000-12		2			0.14
18	3110130	TIIVISTE TÄTNIING SEAL DICHTUNG	USIT R-12 (R3/4")		2			0.01
1-9	3110867	TIIVISTE	TIIVISTE SRJ 160/100		1		1	

LOCTITE 242

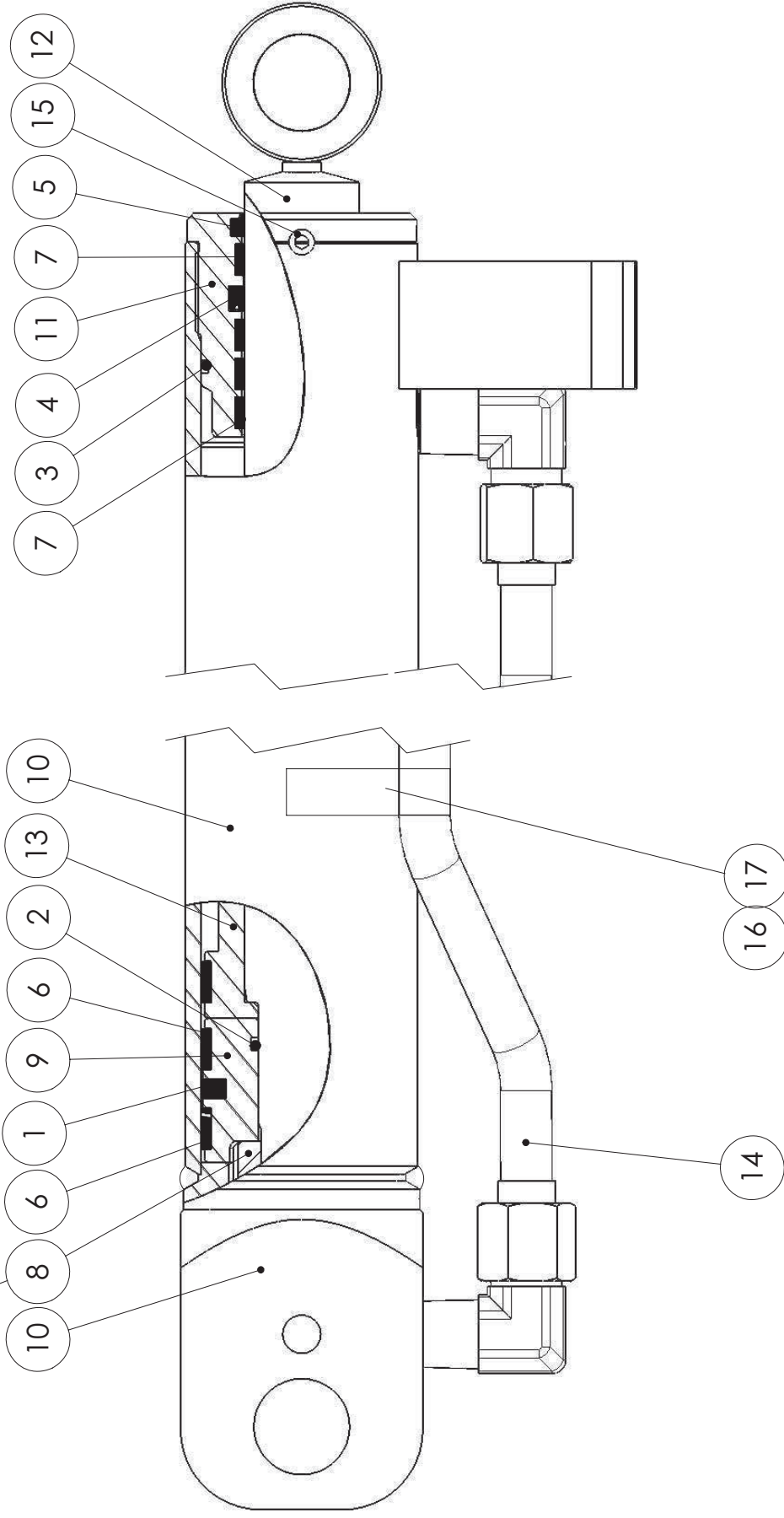

28764001 JATKEEN SYLINTERI

VARAOSAT \ RESERVDELAR \ SPARE PARTS \ ERSATZTEILE



SPARE PART LIST

Item code	28764001	Revision	-
Title	SYLINTERI	Date	30.01.2006
Specification	63/36 X 1700		

Pos	Item code	Title	Specification	Dimensions	Pc	Amount	Unit	Nto Weight
1	3110729	TIIVISTE TÄTNIING SEAL DICHTUNG	SIMKO 300 63/47.5X6		1			0.06
2	3110003	TIIVISTE TÄTNIING SEAL DICHTUNG	O 26.2 X 3 70 SH		1			0.01
3	3110719	TIIVISTE TÄTNIING SEAL DICHTUNG	O 57 X 3 90 SH		1			0.01
4	3110005	TIIVISTE TÄTNIING SEAL DICHTUNG	NI300 36/46X7		1			0.03
5	3110006	TIIVISTE TÄTNIING SEAL DICHTUNG	PW 36		1			0.02
6	3110230	OHJAIN STYRNING GUIDANCE STEUERUNG	E/PWR 63/57X13		3			0.06
7	3110871	OHJAIN STYRNING GUIDANCE STEUERUNG	I/PWR 36/42 X 9.6		4			0.03
8	3020008	MUTTERI MUTTER NUT MUTTER	KM 1" UNF ZN DIN 985		1			0
9	28566201	MÄNTÄ KOLV PISTON KOLBEN	63 (SIMKO300)		1			0.65
10	28764101	SYLINTERIPUTKI CYLINDERROHR	63/36 X 1700		1			19.87
11	28764202	OHJAIN STYRNING GUIDANCE STEUERUNG	63/36	L=72	1			1.03
12	28764204	MÄNNÄNVARSI KOLVSTÄNG PISTON ROD KOLBENSTANGE			1			15.78
13	28764105	HOLKKI HYLSA SLEEVE ACHSHALTER	ISKUNRAJ.	L=67	1			0.67
14	28764401	PUTKI RÖR PIPE ROHR			1			1.7
15	3010175	RUUVI SKRUV SCREW SCHRAUBE	KK M8 X 10 ZN DIN 914		1			0
16	3090928	KIINNIKE FÄSTE FASTENER BEFESTIGUNG	30-ZR-518		1			
17	3090929	LIITIN KOPPLINGSSTYCKE CONNECTOR KONNEKTOR	ABA-085		1			
1-7	3110872	TIIVISTE TÄTNIING SEAL DICHTUNG	SEALING KIT 63/36		1			

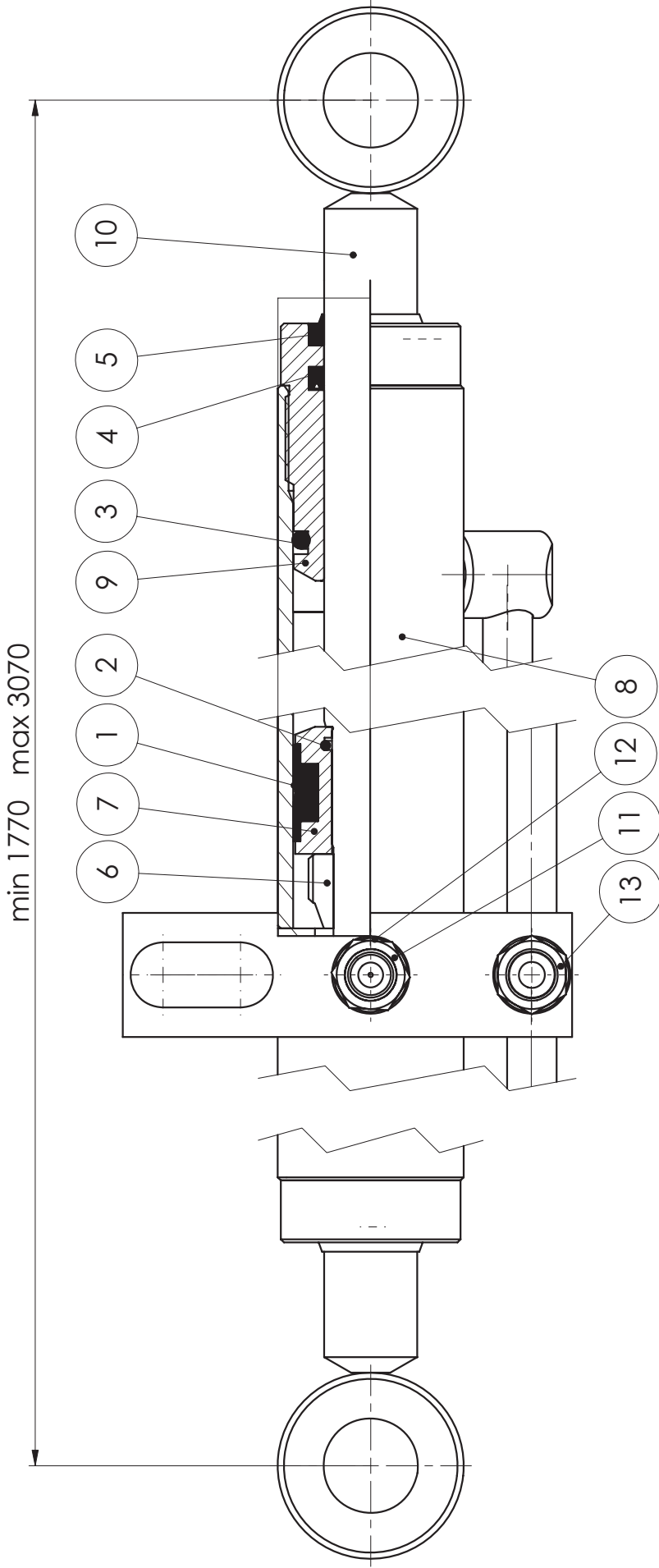

28772001

TUKIJALAN LEVITYSSYLINTERI

VARAOSAT \ RESERVDELAR \ SPARE PARTS \ ERSATZTEILE



SPARE PART LIST

Item code	28772001	Revision	-
Title	SYLINDERI	Date	26.08.2005
Specification	50/30 X 2 X 650		

Pos	Item code	Title	Specification	Dimensions	Pc	Amount	Unit	Nto Weight
1	3110013	TIIVISTE TÄTINING SEAL DICHTUNG	DAS 50/34 X 18		2			0.18
2	3110003	TIIVISTE TÄTINING SEAL DICHTUNG	O 26.2 X 3 70 SH		2			0.01
3	3110288	TIIVISTE TÄTINING SEAL DICHTUNG	O 39.2 X 5.7 90 SH		2			0.03
4	3110030	TIIVISTE TÄTINING SEAL DICHTUNG	NI300 30/40X7		2			0.02
5	3110313	TIIVISTE TÄTINING SEAL DICHTUNG	GA 30/40 X 7/10		2			0.03
6	3020026	MUTTERI MUTTER NUT MUTTER	KM M24 ZN DIN 985		2			0
7	28337201	MÄNTÄ KOLV PISTON KOLBEN	D=50 DBM		2			0.26
8	28772101	SYLINDERIPUTKI CYLINDERÖR CYLINDER BARREL ZYLINDERROHR	50/30 X 2 X 650		1			3.84
9	28337202	OHJAIN STYRNING GUIDANCE STEUERUNG	50/30		2			0.9
10	28772204	MÄNNÄNVARSI KOLVSTÄNG PISTON ROD KOLBENSTANGE			2			0.65
11	28357106	KURISTIN STRYP RESTRICTION DROSSEL	R3/8"	L=57	1			0.12
12	3110040	TIIVISTE TÄTINING SEAL DICHTUNG	USIT R-06 (R 3/8")		2			0
13	3090296	LIITIN KOPPLINGSSTYCKE CONNECTOR KONNEKTOR	04000-06 EP		1			0.07
1-5	3110324	TIIVISTE TÄTINING SEAL DICHTUNG	SAR.JA 50/30		1		sj	

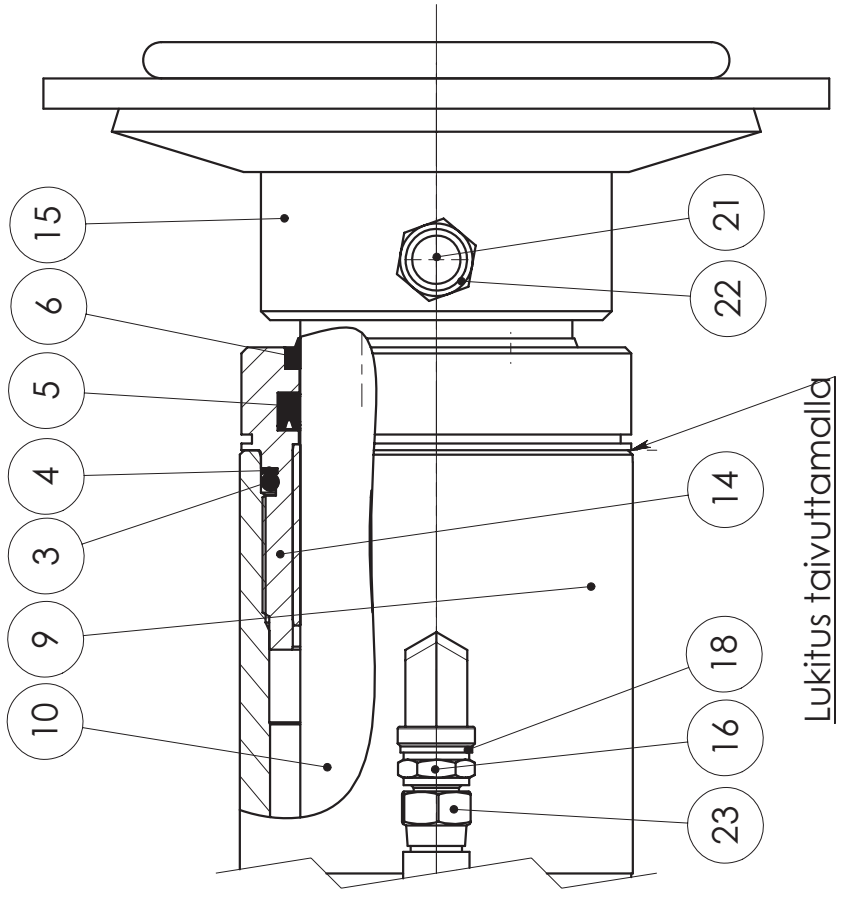
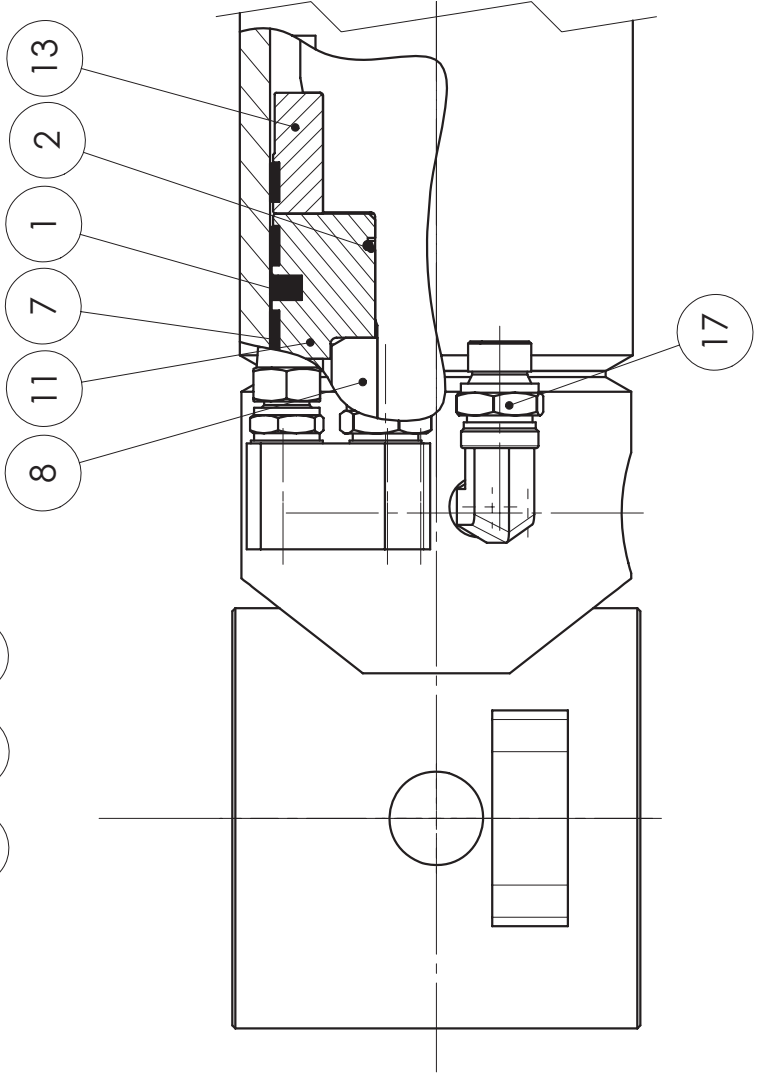
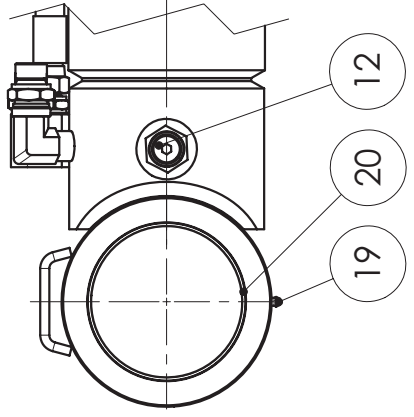

Lukitus taivuttamalla

28773001 TUKIJALANSYLINTERI



SPARE PART LIST

Item code	28773001	Revision	-
Title	SYLINTERI	Date	02.09.2005
Specification	110/90 X 600		

Pos	Item code	Title	Specification	Dimensions	Pc	Amount	Unit	Nto Weight
1	3110757	TIIVISTE TÄTNIING SEAL DICHTUNG	OK 110/89 X 8		1			0.2
2	3110258	TIIVISTE TÄTNIING SEAL DICHTUNG	O 42.2 X 3 90 SH		1			0.01
3	3110626	TIIVISTE TÄTNIING SEAL DICHTUNG	O 104.2 X 5.7 90SH		1			0.07
4	3110627	TIIVISTE TÄTNIING SEAL DICHTUNG	TR 115/105X1.7 PU		1			0
5	3110793	TIIVISTE TÄTNIING SEAL DICHTUNG	HALLITE 90/105X12		1			0.18
6	3110420	TIIVISTE TÄTNIING SEAL DICHTUNG	GA 90X100X7/10		1			0.09
7	3110566	OHJAIN STYRNING GUIDANCE STEUERUNG	E/PWR 110/104X13		3			0.1
8	3020049	MUTTERI MUTTER NUT MUTTER	KM M39 X 3 ZN DIN 985		1			0
9	28773101	SYLINTERIPUTKI CYLINDERROHR	110/90 X 600		1			14.86
10	28773302	MÄNNÄNVARSI KOLVSTÄNG PISTON ROD KOLBENSTANGE	MV 90	L=903	1			
11	28590201	MÄNTÄ KOLV PISTON KOLBEN	110		1			2.5
12	3120843	VENTTIILI VENTIL VALVE VENTIL			1			0.13
13	28773105	HOLKKI HYLSA SLEEVE ACHSHALTER	ISKUNRAJ.	L=43	1			1.39
14	28773202	OHJAIN STYRNING GUIDANCE STEUERUNG			1			3.29
15	28773305	VASTE ANSLAG STOPPER ANSCHLAG			1			6.89
16	3090040	LIITIN KOPPLINGSSTYCKE CONNECTOR KONNEKTOR	04000-06		2			0.06
17	3090001	LIITIN KOPPLINGSSTYCKE CONNECTOR KONNEKTOR	04000-06-08		2			0.08
18	3110040	TIIVISTE TÄTNIING SEAL DICHTUNG	USIT R-06 (R 3/8")		4			0
19	3050003	RASVANIPPA SMÖRJNIPPEL GREASE NIPPLE SCHMIERNIPPEL	M8X1,25 DIN 71412		2			0
20	3100288	LAAKERI LAGER BEARING LAGER	WB802 10040		2			0.25
21	3010104	RUUVI SKRUV SCREW SCHRAUBE	KR M16 X 150 8.8 ZN DIN 931		1			0
22	3020010	MUTTERI MUTTER NUT MUTTER	KM M16 ZN DIN 985		1			0
23	3130832	LETKU SLANG HOSE SCHLAUCH	5701-06/HI98C-06/5701-06/L=640		1			0.42

3091211
SUODATIN

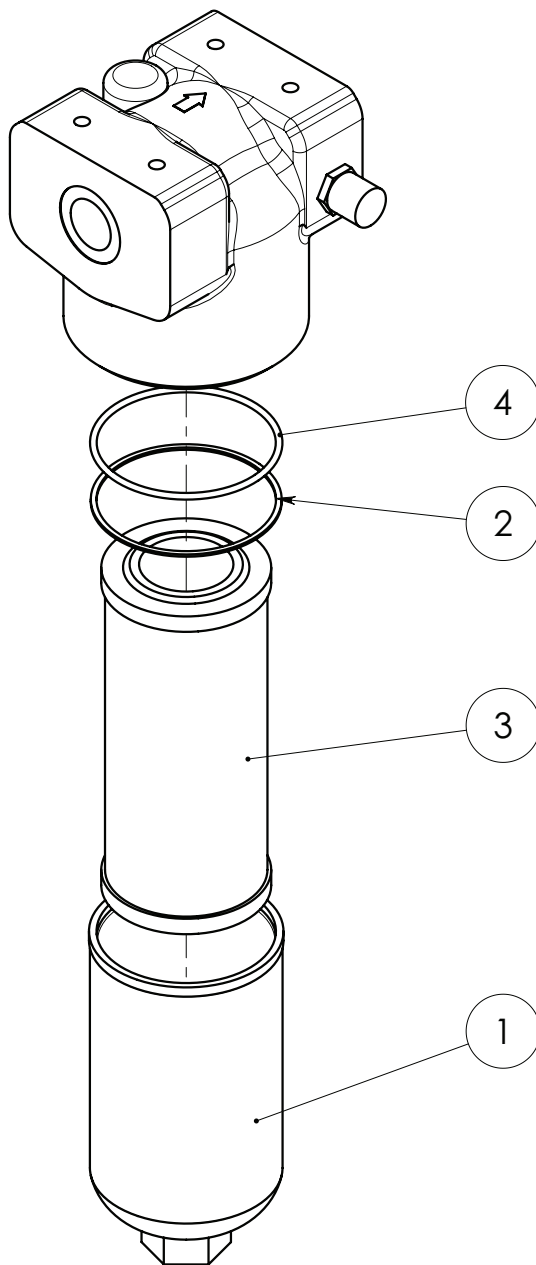



SPARE PART LIST

Item code	3091211	Revision	-
Title	SUODATIN	Date	29.05.2008
Specification	70T220QBPKG161S01		

Pos	Item code	Title	Specification	Dimensions	Pc	Amount	Unit	Nto Weight
1	3090979	SUODATIN FILTER FILTER FILTER	FF7006		1			
2	3110707	TIIVISTE TÄTNING SEAL DICHTUNG	TR 95.1X101.1X1.5 PO-01		1			0
3	3090885	SUODATIN FILTER FILTER FILTER	FC7006.Q020.BK		1			
4	3110706	TIIVISTE TÄTNING SEAL DICHTUNG	O 94.84X3.53 90SH		1			0.02

90022784
KIINNIKE

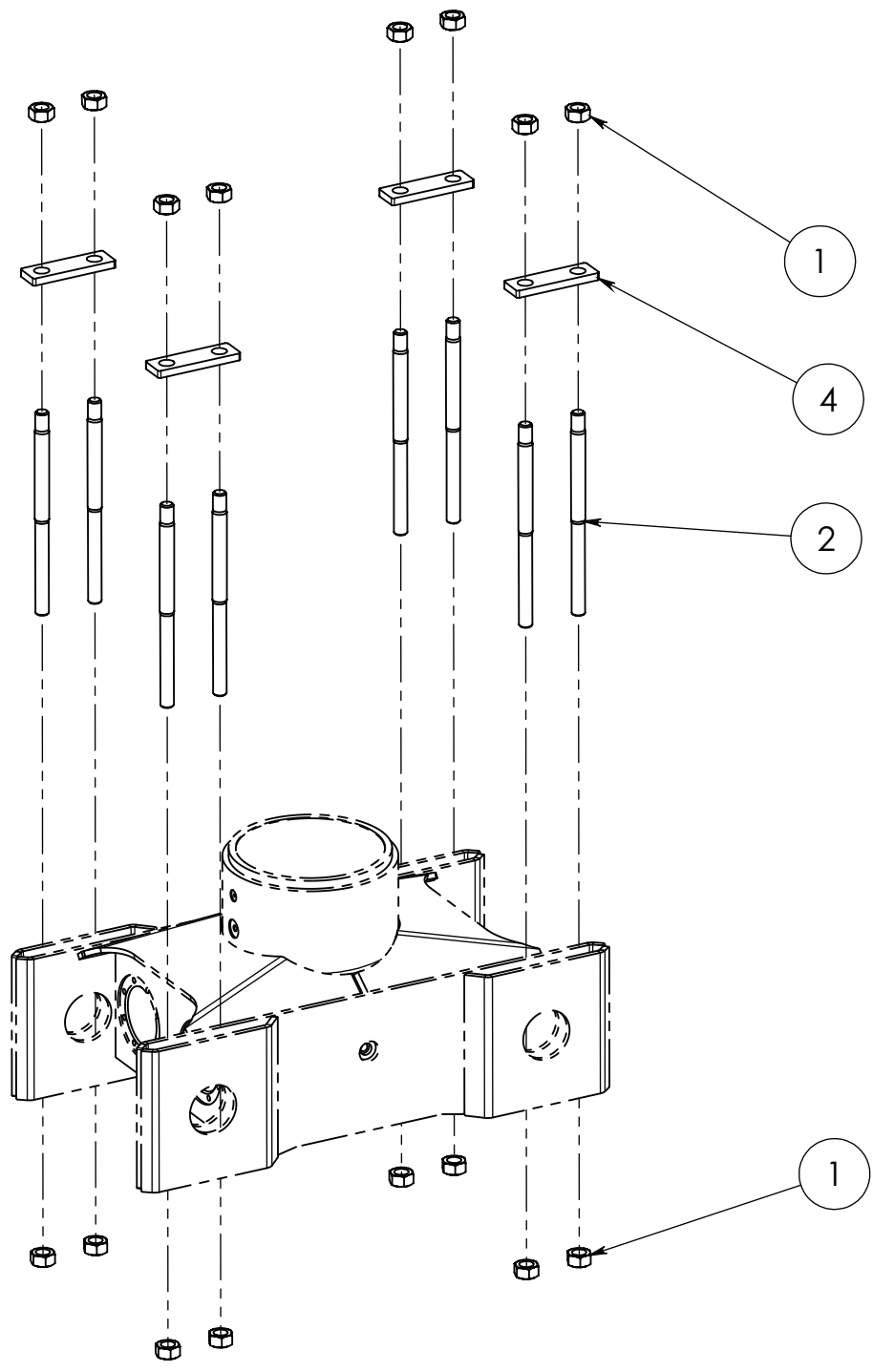



SPARE PART LIST

Item code	90022784	Revision	-
Title	KIINNIKE	Date	26.09.2008
Specification	KESLA 2024 KIINNITYS TEOLLISUUSMALLI		

Pos	Item code	Title	Specification	Dimensions	Pc	Amount	Unit	Nto Weight
1	3020170	MUTTERI MUTTER NUT MUTTER	KM 30 X 2 ZN DIN 934		16			0
2	90019789	RUUVI SKRUV SCREW SCHRAUBE	M30X2-460	L=460	8			2.36
4	90022724	ALUSLEVY BRICKA WASHER UNTERLEGSCHIBE		195x60	4			1.26

90022440
TELINE

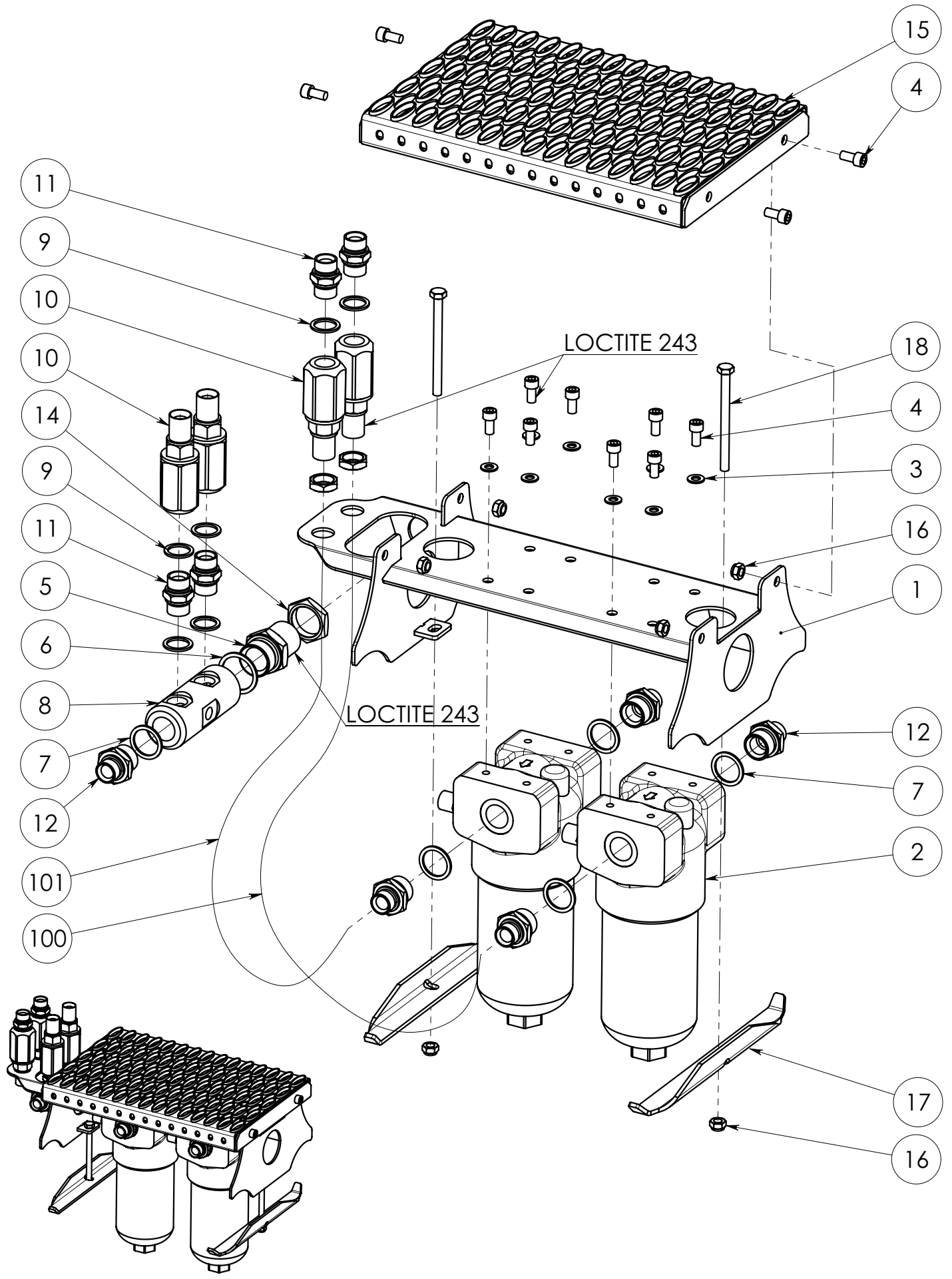

Nimikenumero	90022440	Revisio	-
Nimitys	TELINE	Päiväys	17.03.2008
Specifikaatio	SUODATINTELINE 2024	Liitty	KESLA 2024

Pos	Nimike n:o	Nimitys + Specifikaatio	Mitat	Kpl	Määrä	Yks	Nto paino	Huom
1	90022387	TELINE SUODATINTELINE		1			5.82	
2	3091211	SUODATIN 70T220QBPKG161S01		2			30.50	
3	3030065	ALUSLEVY M10 ZN DIN 125		8			0.00	
4	3010192	RUUVI KKR M10 X 20 8.8 ZN DIN 912		12			0.00	
5	3090396	LIITIN 04000-20 EP		1			0.44	
6	3110849	TIIVISTE USIT R-1 1/4"		1			0.01	
7	3110173	TIIVISTE USIT R-16 (R1")		5			0.01	
8	90021976	LOHKO	L=138	1			1.58	
9	3110130	TIIVISTE USIT R-12 (R3/4")		6			0.01	
10	3091121	LIITIN TEMA 7KR 3/4"/3/4"		4				
11	3090185	LIITIN 04000-12		4			0.14	
12	3090364	LIITIN 04000-12-16		5			0.21	
13	3090301	MUTTERI 1270-12 ZN (R3/4")		2			0.03	
14	3090397	MUTTERI 1270-20 ZN		1			0.08	
15	90021971	TASO HUOLTOTASO HITS		1			3.52	
16	3020004	MUTTERI KM M10 ZN DIN 985		6			0.00	
17	90010239	LAITA	360x55	2			0.59	
18	3010401	RUUVI KR M10 X 130 8.8 ZN DIN 931		2			0.00	
100	3131568	LETKU 5601-12/HI-33-12/5660-12/L=870		1			0.94	
101	3131942	LETKU 5701-12/HI-84-12/5760-12/L=700		1				

90022726

VARUSTELU

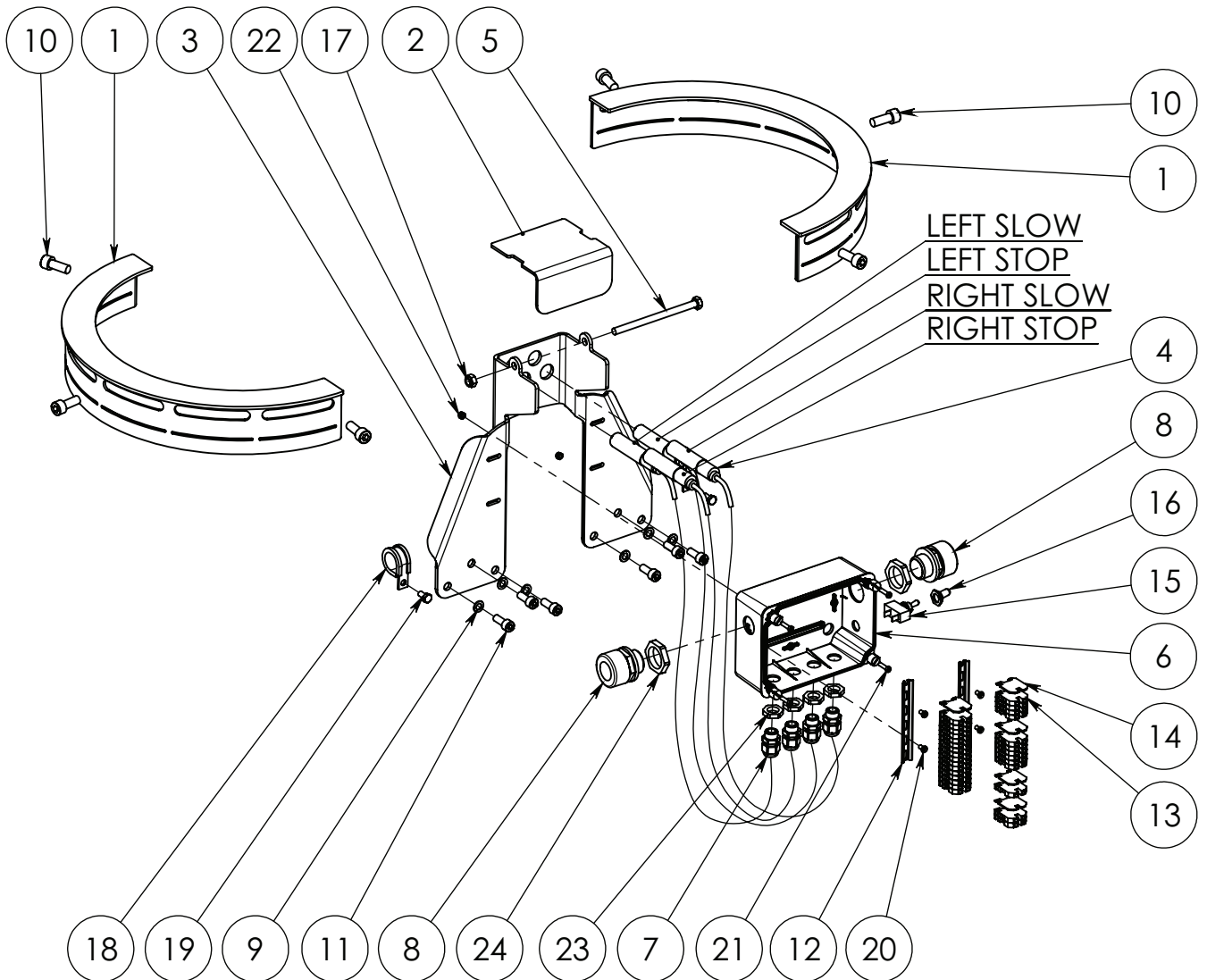
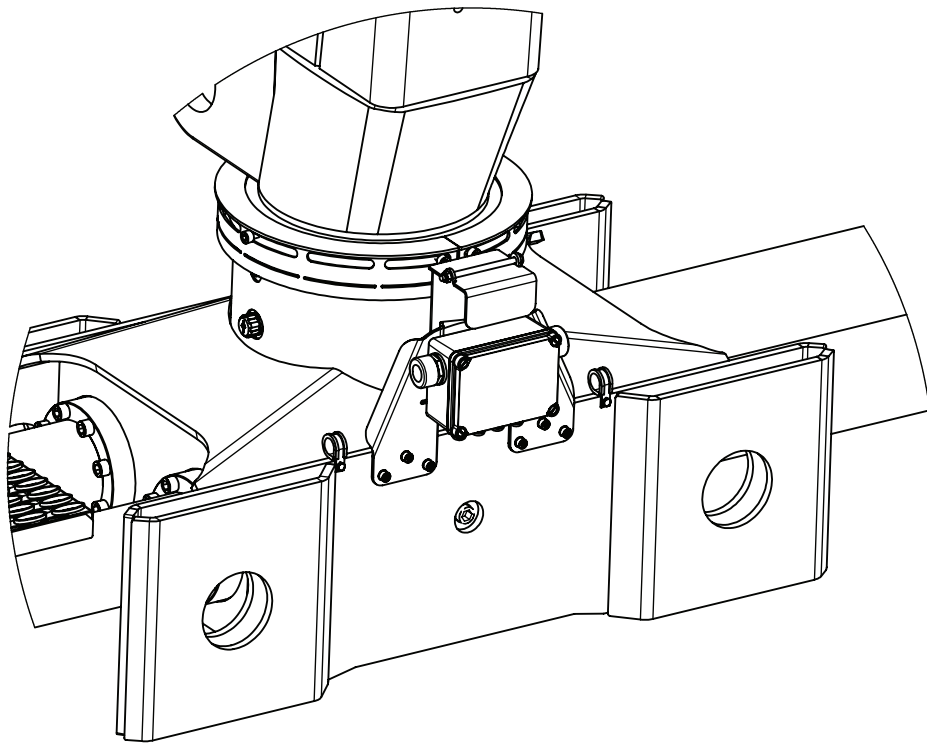



SPARE PART LIST

Item code	90022726	Revision	-
Title	VARUSTELU	Date	23.10.2008
Specification	KÄÄNNÖN RAJOITIN		

Pos	Item code	Title	Specification	Dimensions	Pc	Amount	Unit	Nto Weight
1	90022730	SUOJA SKYDD COVER SCHUTZ			2			1.49
2	90022736	KANSIDÄCK COVER DECKEL		145x110	1			0.37
3	90022731	TELINE STÄLL RACK GESTELL		298x385	1			1.73
4	3181159	KYTKIN KOPPEL SWITCH SCHALTER	OEM 650.2905.023 PNP-30VDC		4			0
5	3010329	KUUSIORUUVI	M 8 x 120 8.8 ZN DIN 931		1			1.17
6	3180306	KOTELO KÄPA BOX DOSE	164 x 99 x 67 PVC 03360		1			0.05
7	3180184	TIIVISTE TÄTNIING SEAL DICHTUNG	PG 9		4			0.24
8	3180007	HOLKKI HYLISA SLEEVE ACHSHALTER	PG 21		2			0
9	3030081	TIIVISTE TÄTNIING SEAL DICHTUNG	M 8		6			0
10	3010685	RUUVI SKRUV SCREW SCHRAUBE	M10 x 25 8.8 ZN DIN 912		6			0
11	3010253	RUUVI SKRUV SCREW SCHRAUBE	M 8 x 20 8.8 ZN DIN 912		6			0
12	3180454	KISKO RÄLS RAIL GLEIS	TS15/F LEV. 15 MM		2		m	0.02
13	3180496	LIITIN KOPPLINGSSTYCKE CONNECTOR KONNEKTOR	RK 1.5-4/15 PA 1010.2		29			0.03
14	3180497	LIITIN KOPPLINGSSTYCKE CONNECTOR KONNEKTOR	AP 1.5-4 2738.2 BEIGE		5			0.01
15	3180730	KYTKIN KOPPEL SWITCH SCHALTER	APEM 631H/2 1 NAPA ON / OFF		1			0.01
16	3180679	SUOJA SKYDD COVER SCHUTZ	600H U851		1			0
17	3020001	MUTTERI MUTTER NUT MUTTER	M 8 ZN DIN 985		1			0.05
18	3090261	PIDIKE FÄSTE HOLDER GESTELL	LEP-22		2			0
19	3010585	RUUVI SKRUV SCREW SCHRAUBE	M 6 x 12 ZN 8.8 DIN 933		2			0
20	3010732	RUUVI SKRUV SCREW SCHRAUBE	3.5 x 8 DIN 7981		4			0
21	3010324	RUUVI SKRUV SCREW SCHRAUBE	M 4 x 16 ZN DIN 84		4			0
22	3020093	MUTTERI MUTTER NUT MUTTER	M 4 ZN DIN 985		4			0
23	3181160	VASTAMUTTERI [SWEI707] [ENG1707] [GER1707]	PG9		4			
24	3181161	VASTAMUTTERI [SWEI707] [ENG1707] [GER1707]	PG21		2			
100	3180012	HOLKKI HYLISA SLEEVE ACHSHALTER	ERISTÄMÄTÄN 0.75		58			
101	3180812	KAAPPELI KABEL CABLE KABEL	S200 18 x 0.75 MM2		1	6.5	m	

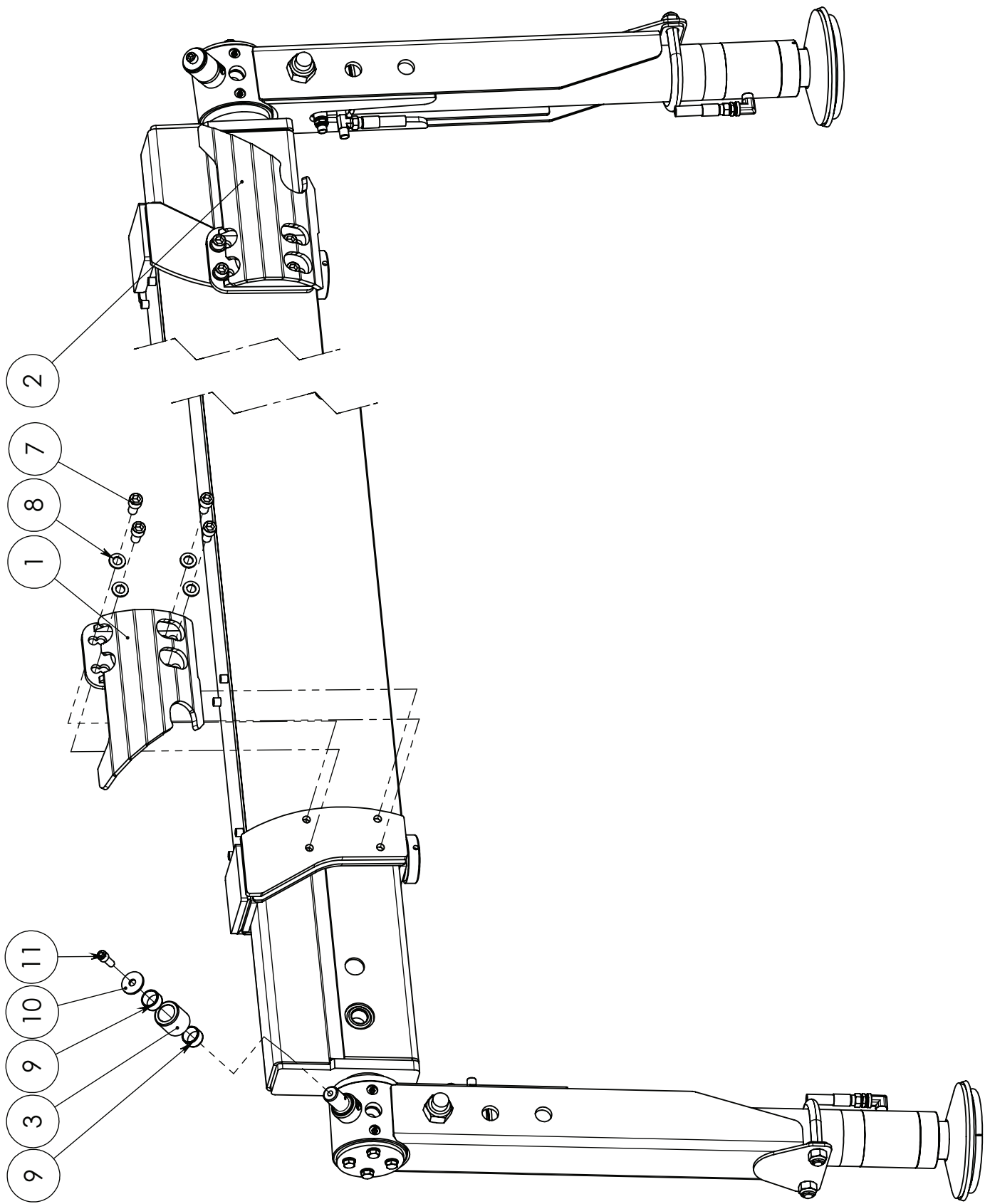

90021453



SPARE PART LIST

Item code	90021453	Revision	-
Title	VARUSTELU	Date	01.11.2006
Specification	HEITTOLEVY		

Pos	Item code	Title	Specification	Dimensions	Pc	Amount	Unit	Nto Weight
1	90020239	JOHDE LEDARE CABLE KONDUKTOR	HITS VASEN		1			5.82
2	90020238	JOHDE LEDARE CABLE KONDUKTOR	HITS. OIKEA		1			5.82
3	90012841	HOLKKI HYLSA SLEEVE ACHSHALTER	50/34-50		2			0.41
4	90020807	LIUKUPALA GLIDKLACK GLIDE PAD GLEITLAGER		L=9	2			0.05
5	3030096	ALUSLEVY BRICKA WASHER UNTERLEGSCHEIBE	M12 ZN DIN 125		8			0.01
6	3010048	RUUVI SKRUV SCREW SCHRAUBE	M12X30 8.8 ZN DIN 933		8			0
7	3010700	RUUVI SKRUV SCREW SCHRAUBE	M16X30 8.8 ZN DIN 912		8			0
8	3030054	ALUSLEVY BRICKA WASHER UNTERLEGSCHEIBE	M16 ZNC H225 DIN 125		8			0.01
9	3100124	LAAKERI LAGER BEARING LAGER	PM 3020 DX		4			0.03
10	3030122	ALUSLEVY BRICKA WASHER UNTERLEGSCHEIBE	M12 ZN DIN 440		2			0
11	3010246	RUUVI SKRUV SCREW SCHRAUBE	M12X30 8.8 ZN DIN 912		2			0